

WELCOME TO



TRIZ Automations & Robotics Pvt. Ltd.

SPM, Conveyors, Pick & Place, Material handling Systems,
Automations & Robotic Applications,
All Types of Customised Machine Design and Manufacturing

Gat No. 709, Near Velu Phata (Shindewadi),
Pune-Bangalore highway, A/P Velu, Tal- Bhor,
Pune. Maharashtra-412205.
Website: www.trizsystems.com

TRIZ Automations & Robotics Pvt. Ltd. is Established in 2009 and being Directed & Managed by Mr. Mahadeo Pawar. He has work experience of automation companies like PARI (Precision Automation and Robotics India Ltd.), TAL, Nichrome, Taikisha, Epcos, TDK, in Mechanical Design.

He has also worked with various multi-national companies and has got over 20 years of experience in the fields of Engineering Design & manufacturing of the equipments, Process, Project Planning, execution & Controls. He has acquired the specialization in Critical Machine Designs, SPM designs and it's manufacturing as per customer requirement in Triz Automations & Robotics Pvt. Ltd.

Mission : - To become the most preferred source for all our customers by providing excellent services consistently & to be always competitive in respect of quality, cost & delivery.

Vision :- Continue to be an innovative Leader, Providing the widest product selection, finest quality and Most affordable newly constructed products. And to achieve the growth of 40% per annum for the next 3 years.

Values: - Customer is the most important guest in our premises. To maintain complete transparency & deal fairly with our customers.



Location of the company :-

Gat No 709, VELU PHATA, PUNE- BENGLORE HIGHWAY, VELU, TAL- BHOR, Pune- 412 205 .(M.S.) India.

Work details :-

Special Purpose Machines, Automations, Conveyors, Gantries, Pick and Place Systems, Material Handling Systems.

Set up details:-

Drill Machines, lathe Machine, Co2 Welding Machines, Argon Welding machine, Arc Welding Machines, Surface plate, Height Gauge, Venires, Hand drill machines, Hand Grinders, Air compressor, Painting, Crane service, Gas Cutting etc..

All type of Machining grinding facilities are available in front of our shop only.

Work space available:-

Work Shop 8000 Sq. Feet on Pune-Banglore Highway, Shindewadi, Pune.

Office Area – 3000 Sq. – 2 floors.

Engineering facilities :-

In house Engineering Design Facility – Expert Design Engineers and Drafting Engineers – Total 8 Nos.

Software's and workstations - Solid Edge , Solid Works, Cad inventor, Autocad 2020.

Office Area – 3000 Sq. – 2 floors.

Basic facilities :-

In house Fabrication facility for of M.S. and S.S. structures.

Vendors / suppliers within 10 km radius for Machining, Grinding, slotting, heat treatments, powder coating, plating and Finishing etc.

Complete Trial testing facility with compressed air @ 6 bar and 50 H.P Electrical Power.

Approved Welders , Experienced Fitters, Skilled Helpers, Project engineers, Quality Control Engineer, Project Head..

Employee details:--

Total no of employee =32 Nos.

- | | |
|----------------------------------|----------------------------|
| 1) Machine Design Staff = 8 nos. | 2) Vendor Purchase = 3 Nos |
| 3) Project Engineers = 2 nos. | 4) Welder = 5 Nos. |
| 5) Fitters = 4 Nos. | 6) Helpers = 9 Nos. |
| 7) Accountant = 1 Nos. | 8) Sales = 2 Nos. |
| 9) QA Engineer = 1 No. | |

Our Facility photo's @ Pune



Our Engineering Design Facility

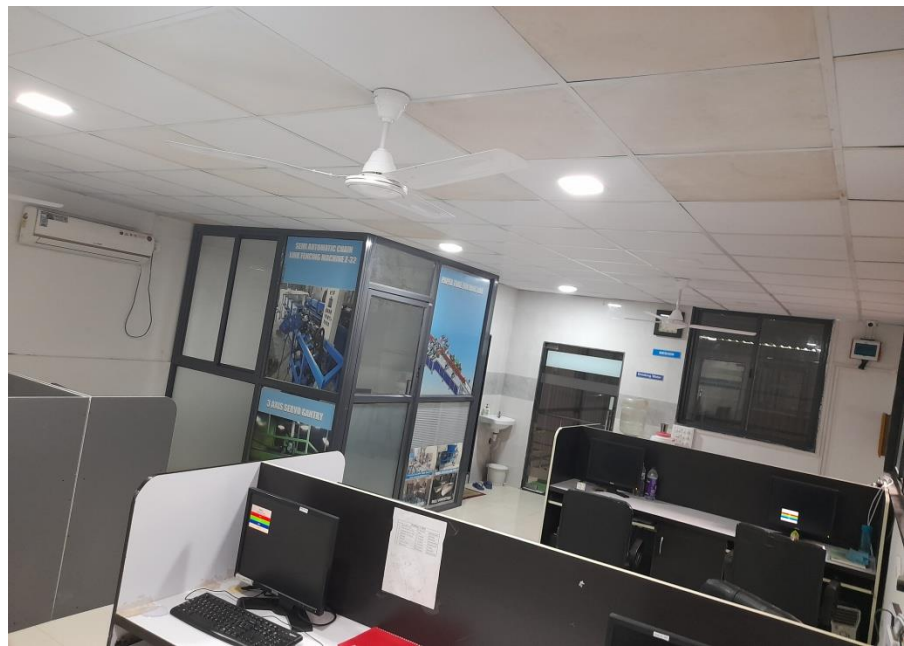
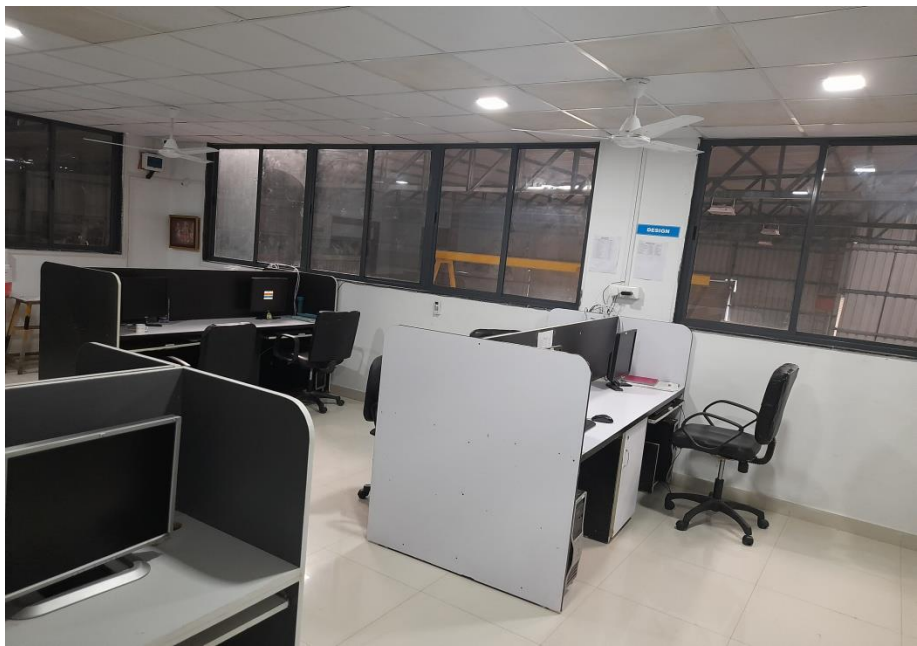
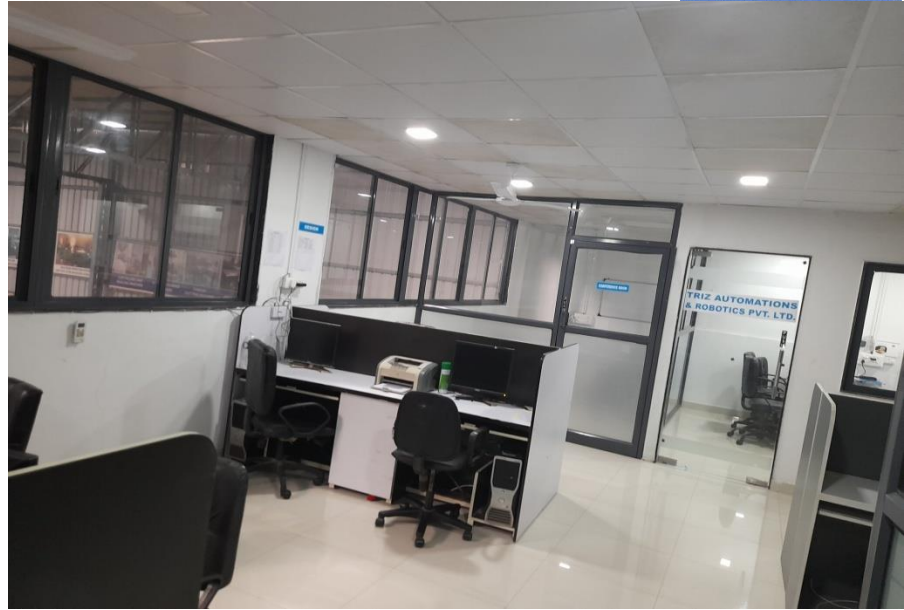

*Some Applications For
SPM & Automations*

EL DRIVE ASSEMBLY LINE



- EL-DRIVE IS USED IN ELECTRICAL CIRCUIT BRAKERS.
- THIS ASSEMBLY CONTAINS @78 PARTS.
- OUR THIS ASSEMBLY LINE IS HAVING 8 PALLET STATIONS ON TOP LAYER OF CONVEYOR .
- PALLET RETURN LINE IS FROM BOTTOM SIDE.
- TWO LIFTERS AT EITHER END ARE USED FOR PALLET TRANSFER
- BEST SYSTEM WITH ANDON DISPLAY CONTROLLER FOR LINE STATUS MONITORING.
- 5 MINS. IS LINE TACK TIME, AFTER 4.5 MINS. SYSTEM GIVES ALARM TO OPERATOR FOR INDEXING.
- IF ANY ISSUE THEN OPERATOR CAN HOLD THE LINE OTHERWISE UPON RECEIVING ALL WORK OVER SIGNALS LINE WILL BE INDEXING.
- ALUMINIUM EXTRUSION AND POWER & FREE CHAIN IS USED FOR PALLET CONVEYOR

*3 Axis Gantry System for AUTO VENT POKING
At Mahindra & Mahindra, Kandivali*



*3 Axis Gantry System for
Palletizing*



*2 Axis Servo Gantry Robots and Pneumatic Pick and Place Units
for Machine Loading and Unloading*

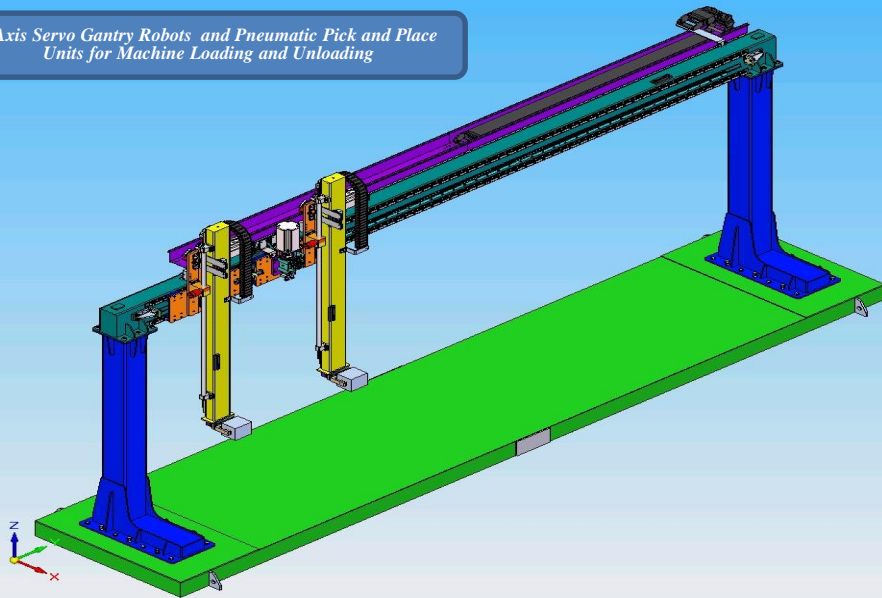

*2 Axis Pneumatic Pick and Place Units
for Machine Loading and Unloading*

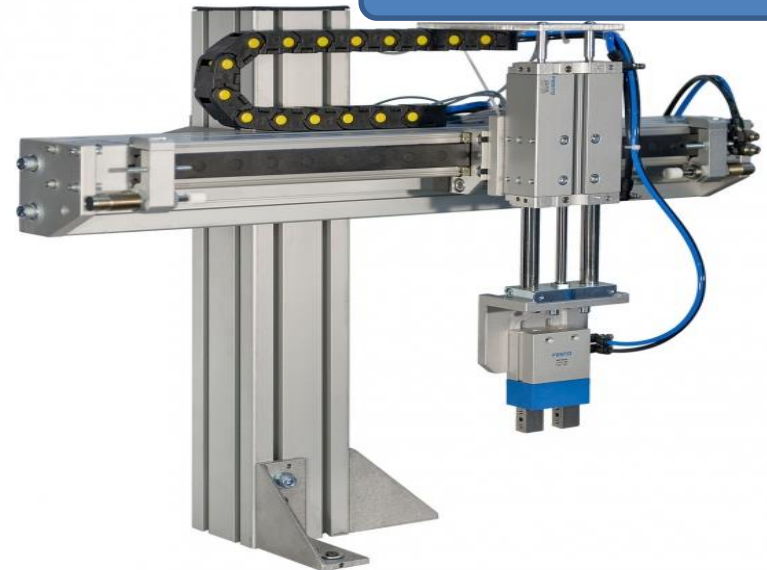

Slat Conveyor and Lifter for Inner boom and Outer boom Insertion system-JCB Crane

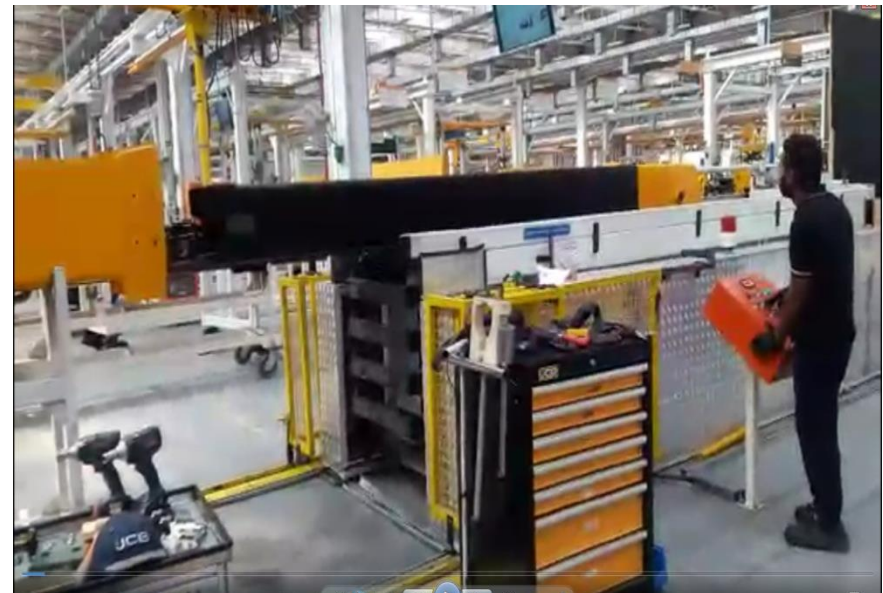

Filter Painting Line Conveyors, Auto Loading, Auto Unloading of Filters and Spinning in Booth and Oven rotation for the process requirement

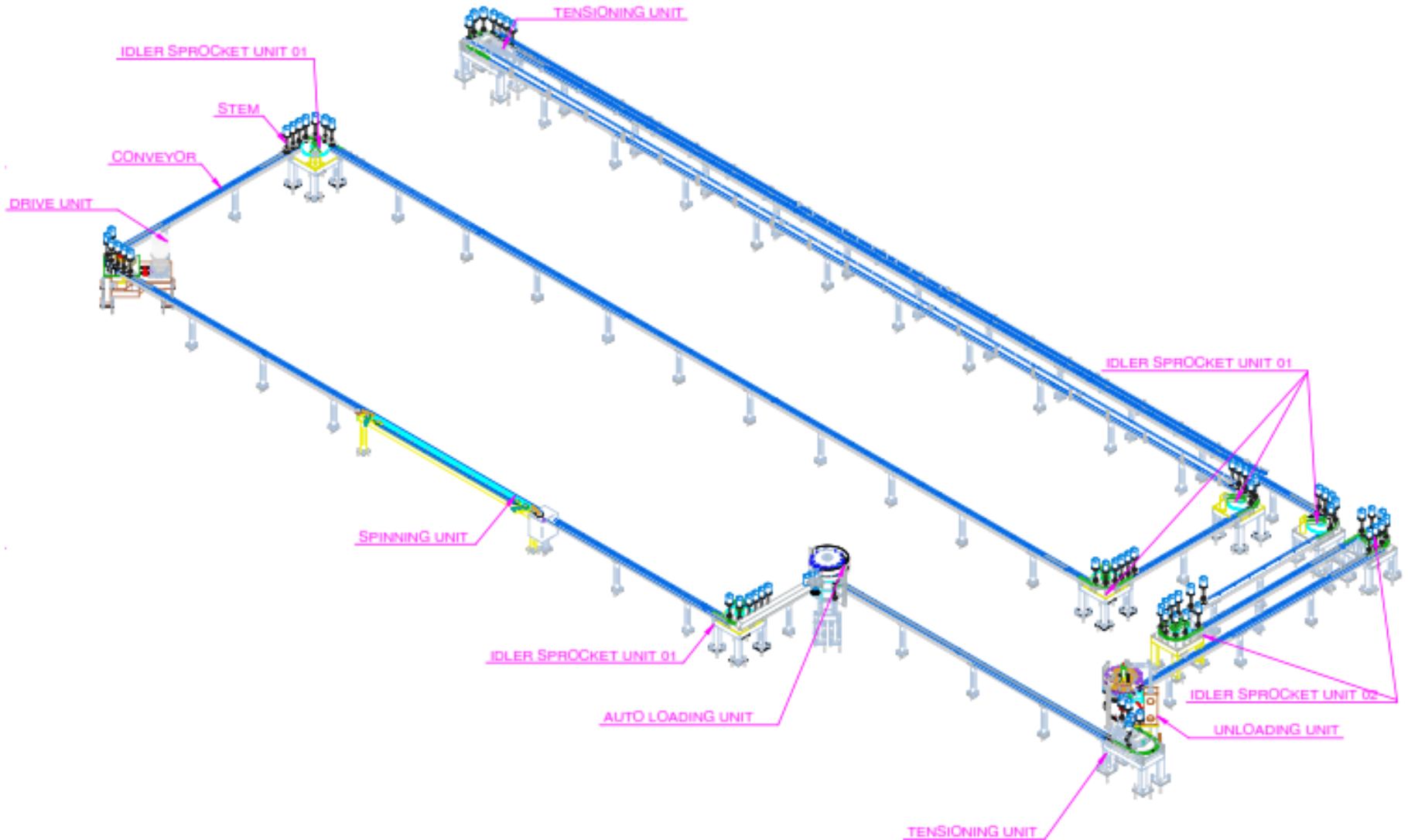

Filter Painting Line Conveyors, Auto Loading, Auto Unloading of Filters and Spinning in Booth and Oven rotation for the process requirement



Filter Painting Line Conveyors, Auto Loading, Auto Unloading of Filters and Spinning in Booth and Oven rotation for the process requirement





Roller Conveyor and Palletizer (For LG washing machine Packing Line)



Y- Type Polyamide Chain conveyors for Milk Crate Handling



TS TOP Chain – Stainless Steel Chain Conveyor For handling Hot Filters

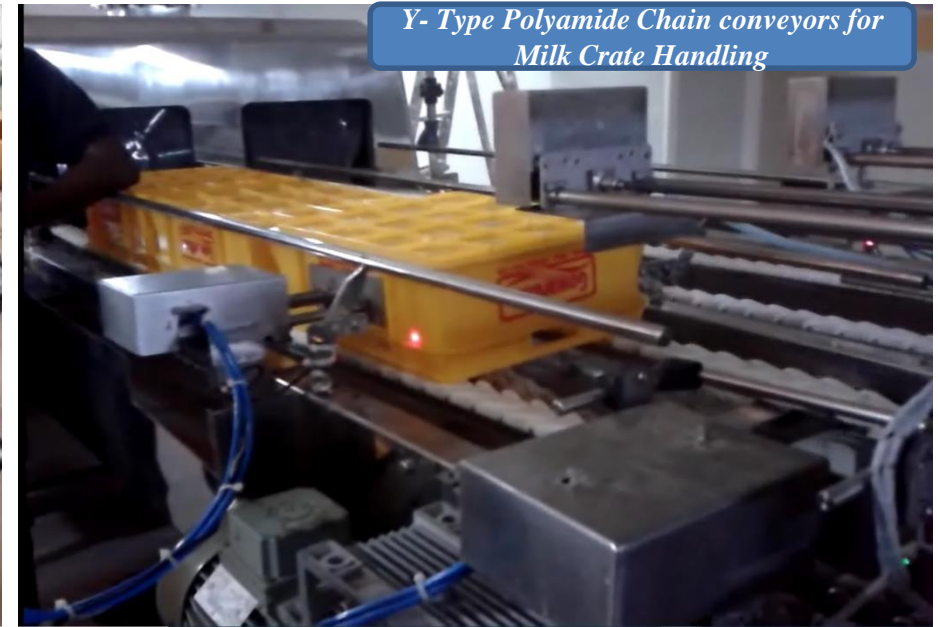

Y- Type Polyamide Chain conveyors for Milk Crate Handling

Flexible and Spiral Roller / belt Conveyors



Spiral Belt Conveyors



Spiral Roller Conveyors

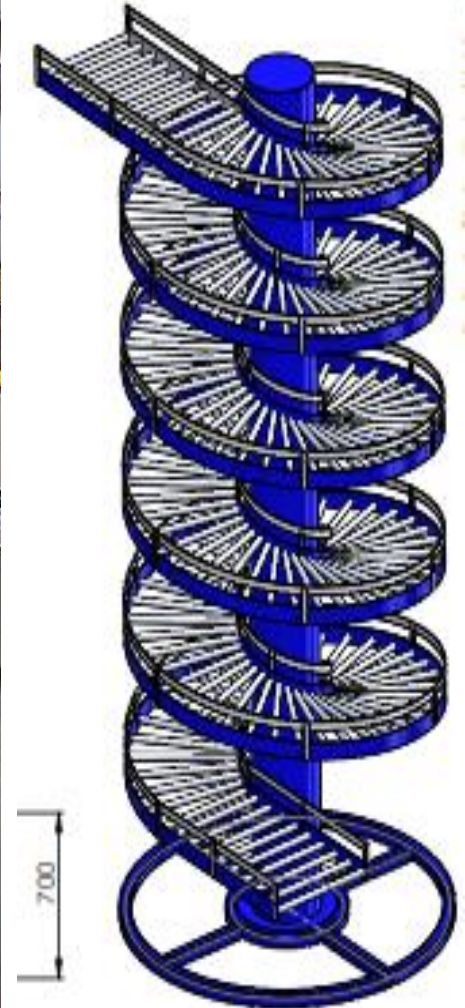

*Chip / burr / Scrap Carrying Conveyors
(Suitable for Laser Cutting Machines, plasma cutting, punching presses and other chip producing applications)*



Belt Conveyors for all type of applications

Plane Belt Conveyor – M.S. Structure



Plane Belt Conveyor – Aluminium Structure



Pallet Handling Chain Conveyors – Power and Free



BELT Conveyors for Special Applications



Belt Conveyor For Tea bag Handling



Split Roller Conveyor –Wheel Rim Handling



Conveyor –for Truck loading / Unloading

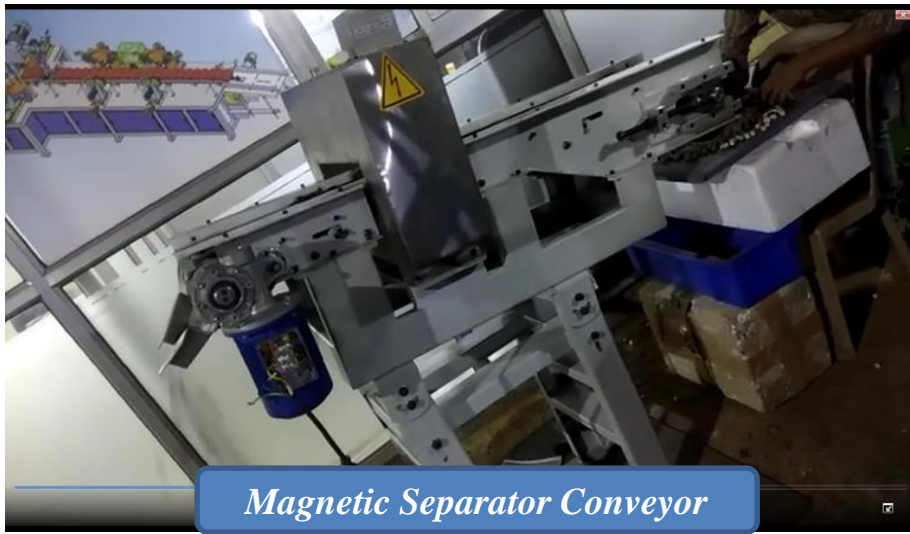

Magnetic Separator Conveyor



Food Grade Conveyors

NON Woven Fabric Strip Cutting machine



Gripper / End Effectors On Robot

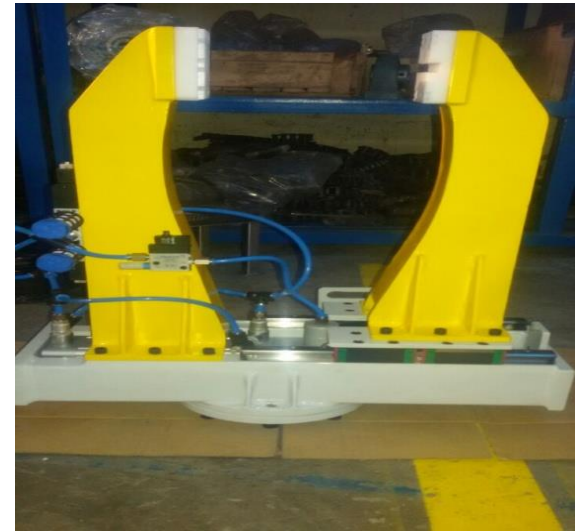

Segmentation Machine for Distillation Columns



De-coiler



Filter Wrapper Edge Bending and Rolling Machine



Filter Wrapper Cone Rolling Machine



*Lifting Platforms,
(For Railway coach End wall Welding Access)*

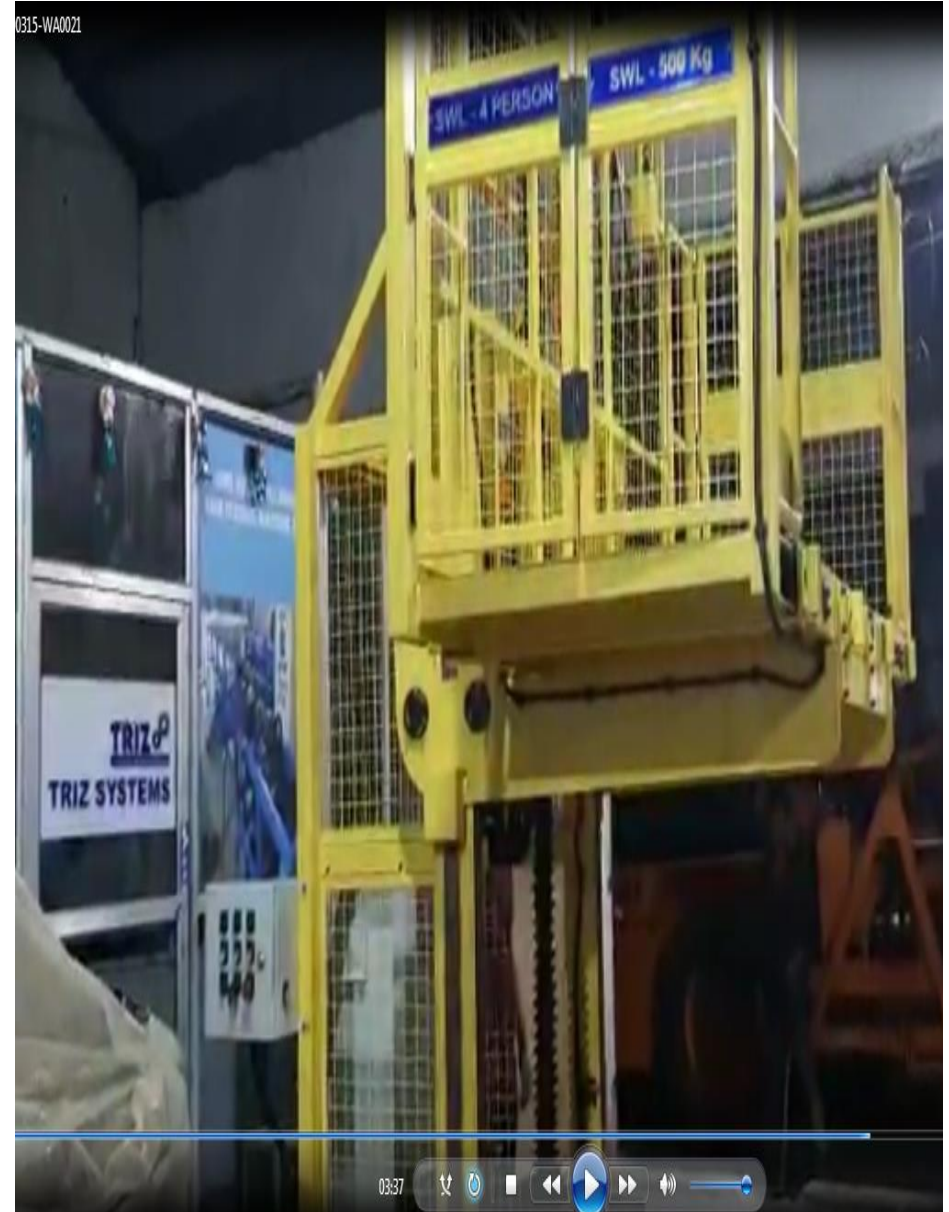

Hydraulic Scissor lifts – 200, 500, 750, 1000, 2000, 3000, 5000 KG.



Roll Stackers, Lift and Rotate – upto 1000kg.



Tilting and rotating Manipulator Hydraulic System– Capacity – 2000kg



Hydraulic Autoloader by hopper lift and tilt– 500kg



Hydraulic Bush Pressing– 2000kg



Chassis Manipulator - 2 Ton Capacity



Riser Lifter For Paint Shop



Mobile Platform Trolleys



Jib Arm Trolleys



Chain Link Fencing Machines



Corrugated Box Packaging Automation – Flap Closing, Auto Taping, Weighing, Sorting & Auto Labeling



Slider Rails Formation and Assembly Machines



Gauging and sorting of valve bodies



PALLET CONVEYORS



DRILLING MACHINES



*Paint Shop feeding Application – Shuttle Trolley
For JCB kitting Part Feeding for Painting line.
Trolley Capacity- 10 tons @ 10 MPM speed.*

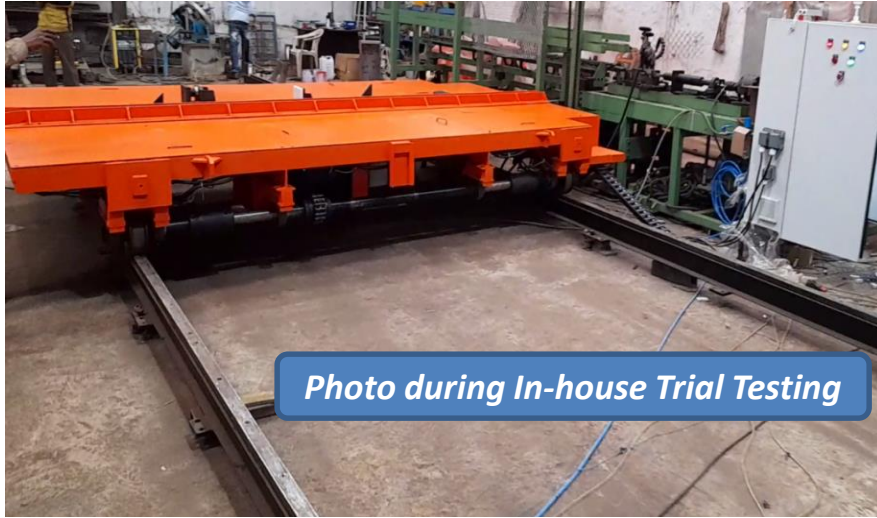

Photo during In-house Trial Testing

Bar / billet handling Systems



Bar Finishing Systems



Safe handling Systems



Automatic Bar End Chamfering Machine – Both ends of round bars Ranging from Dia. 30 to Dia. 150mm Chamfering During Continuous movement of bars.



Automatic Bar End Chamfering Machine – Both ends of round bars Ranging from Dia. 30 to Dia. 150mm Chamfering During Continuous movement of bars.



Sleeve Shrinking Machine, Rubber Sleeve Shrinking by hot air
This is for protection of ground shafts in transportations



M.S. Sheet – Slider + Stacking Table



Coil Spring Scragging & Fatigue Testing Machine.



*Some Applications for
Dairy Industries*



Automatic Cup / Tub filling and Sealing Machine. Suitable for Cheese, Curd, Ice-cream etc.



Antifungal liquid Spraying Machine



Cheese Cooking Machine- Capacity 300lit.



Cheese Blender- Capacity 150lit.



Cheese Grinder



TRIZ
Inventive Problem Solving

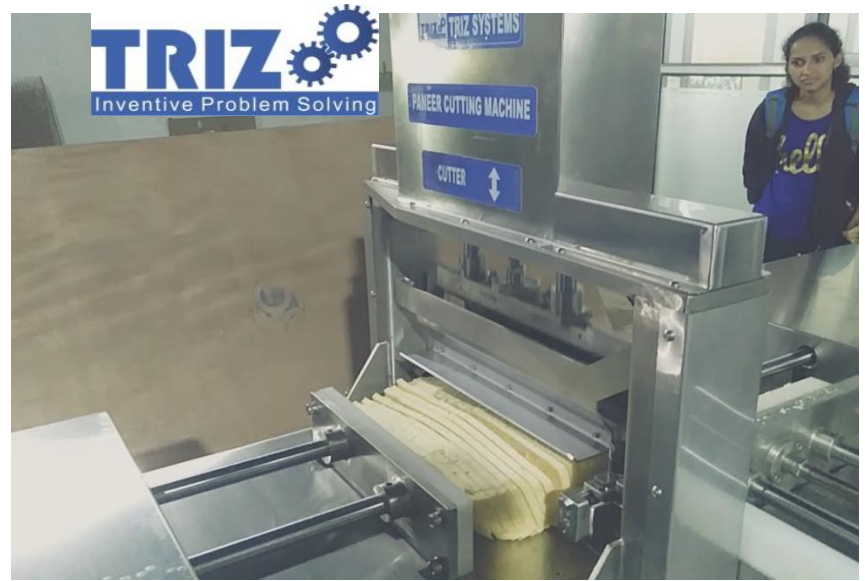

Crate Handling and Lifter Systems



Paneer / Cheese Slice Cutting Machine



Paneer / Cheese VAT



Paneer / Cheese Block Cutting machine



Paneer Pressing – Pneumatic Double Head Machine



Paneer / Cheese Cube Cutter



*Some Applications for
Pharma Industries*

Bottom Disc Lifting Trolley – foot operated , Hydraulic – Capacity -@200 kg



Bottom Disc Lifting Trolley Fork Type – foot operated , Hydraulic – Capacity -@200 kg



*Some Applications for
Foundry Industries*

*3 Axis Gantry System for AUTO VENT POKING
At Mahindra & Mahindra, Kandivali*



Hot Metal Pouring Ladles And Automatic Systems



Inoculation feeder





Free Standing Compaction Table



Manual Moulding Loop

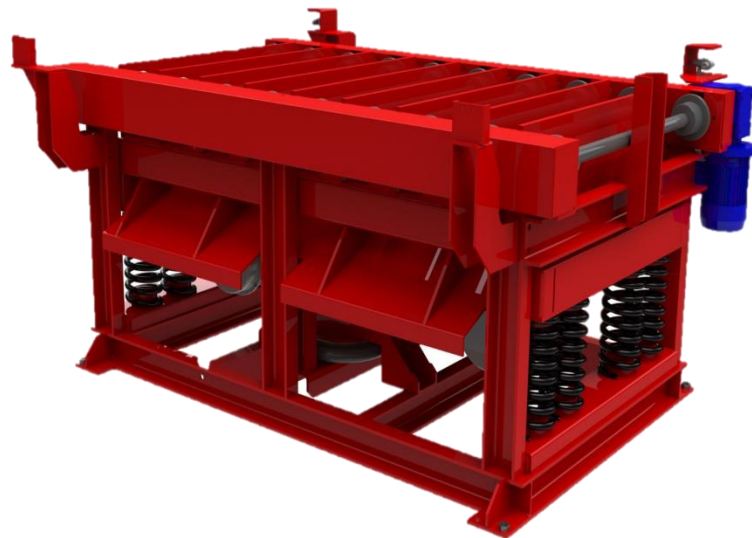

Compaction Table for Mechanised line

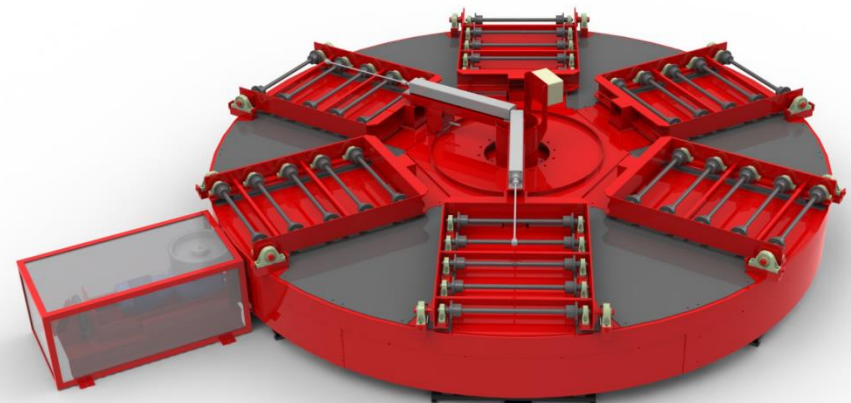

6 Station Carousel for Moulding

Tentative images of Some Applications in Foundry Industries

Carousal with Pivotal Mixture and Rollover

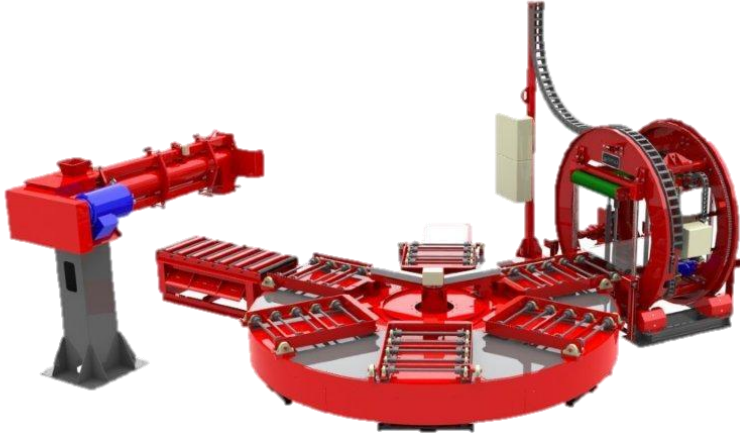

Proposed Plant Layout

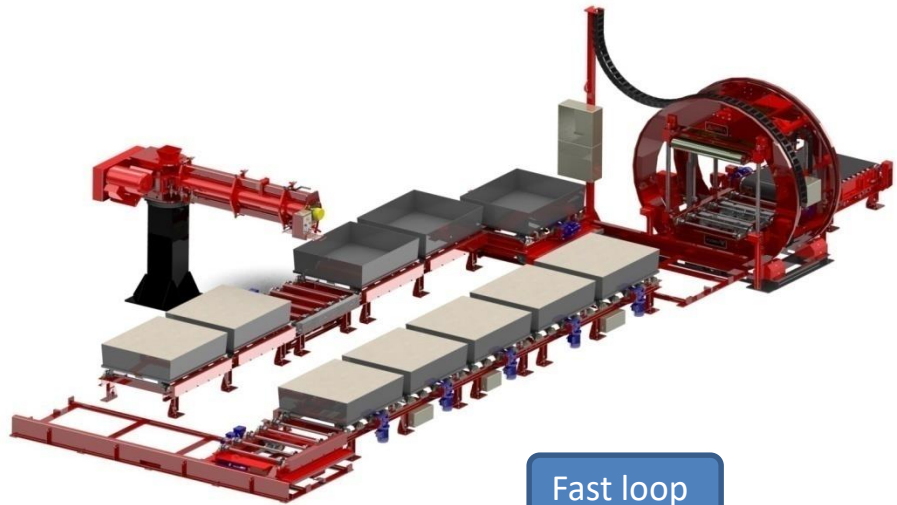
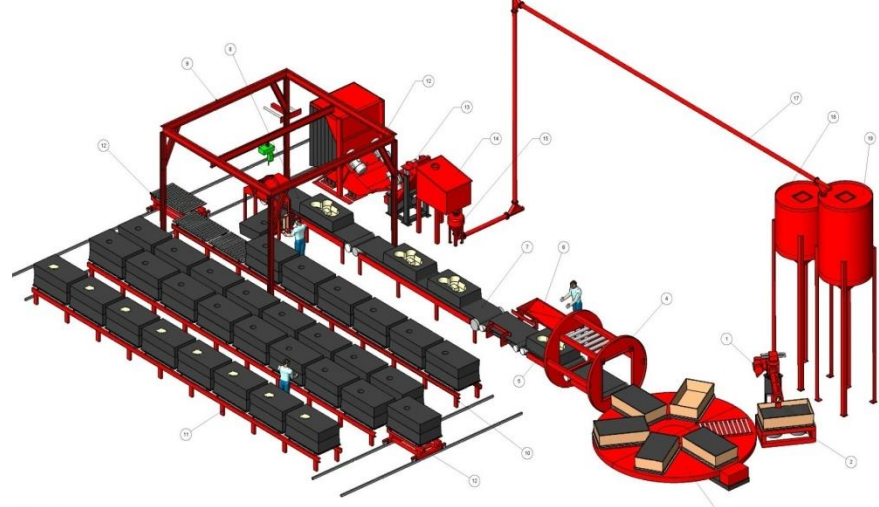

Fast loop

Cold Box Core Shooter Machines - Capacity -@ 100 Lit



Bottom Pouring Machine for Hot Metal Pouring Applications -@ Madras Engineering

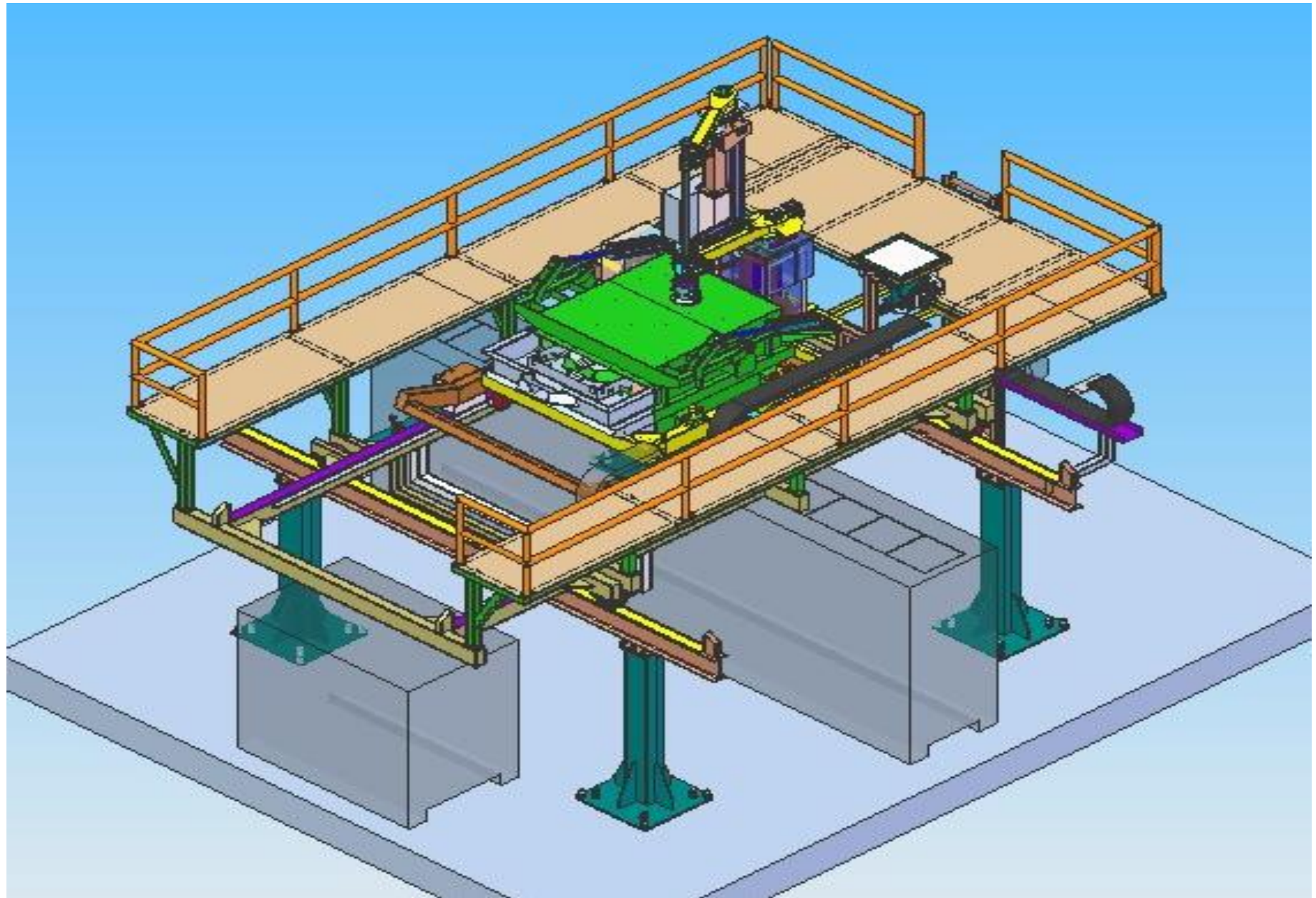

SAND CORE PICK AND PLACE MACHINE FOR MOULDING LINE

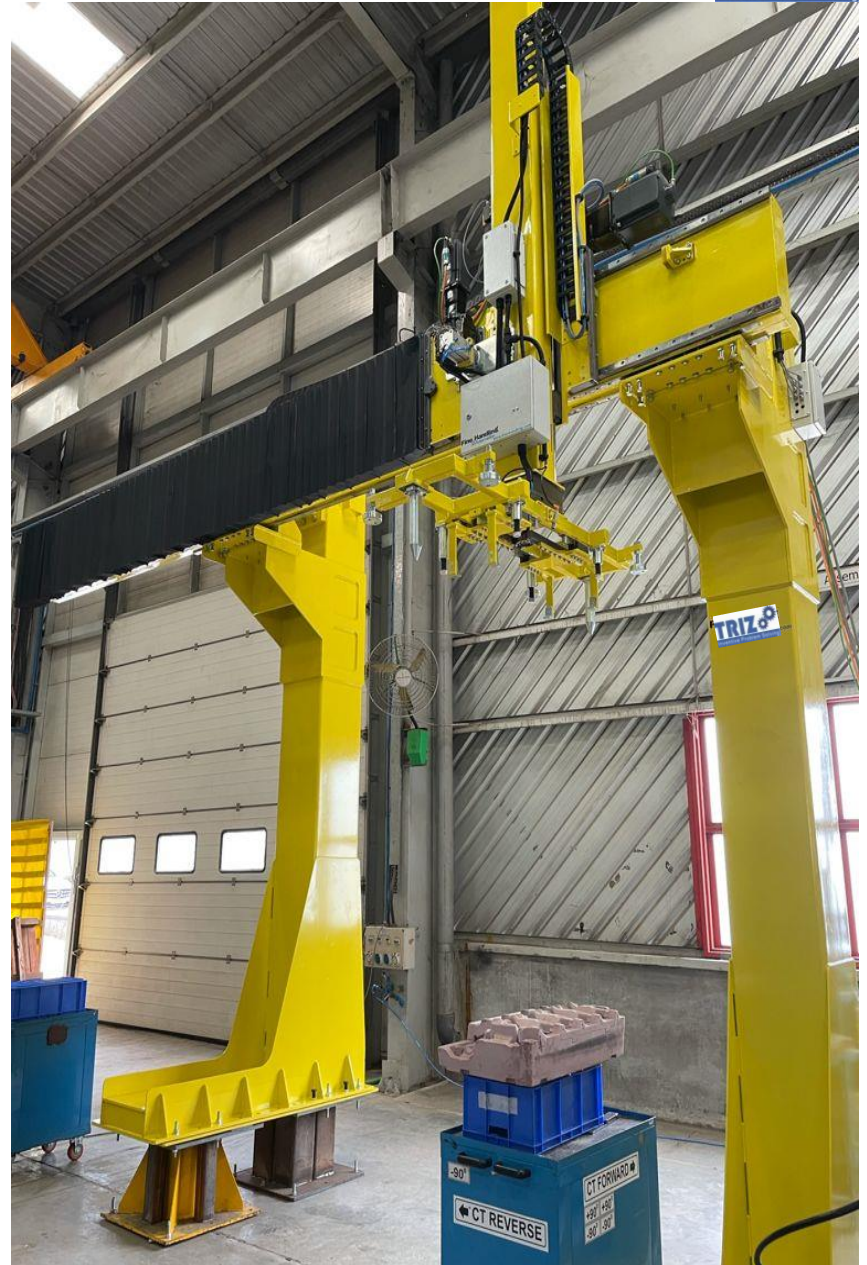
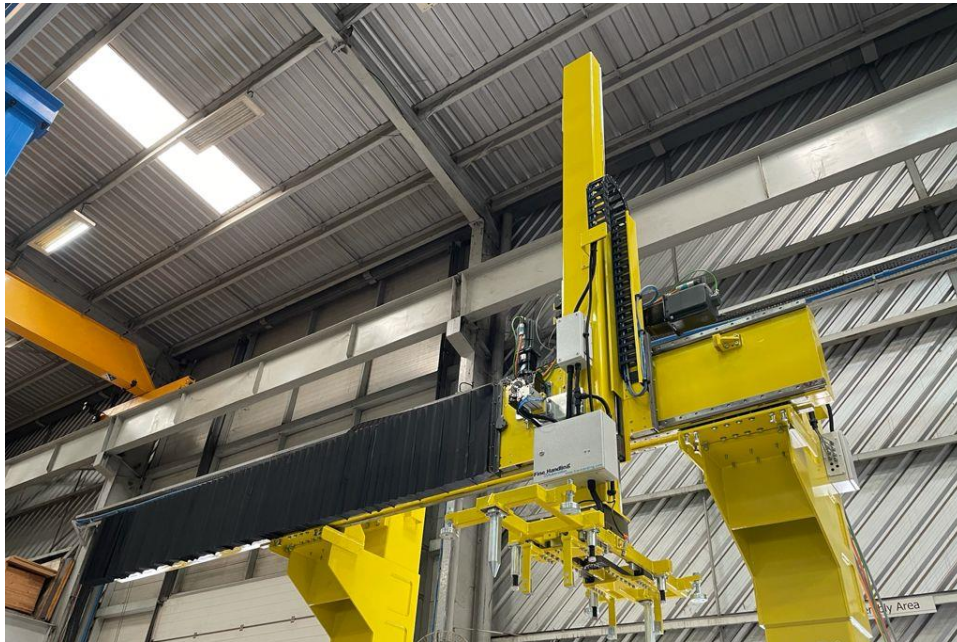
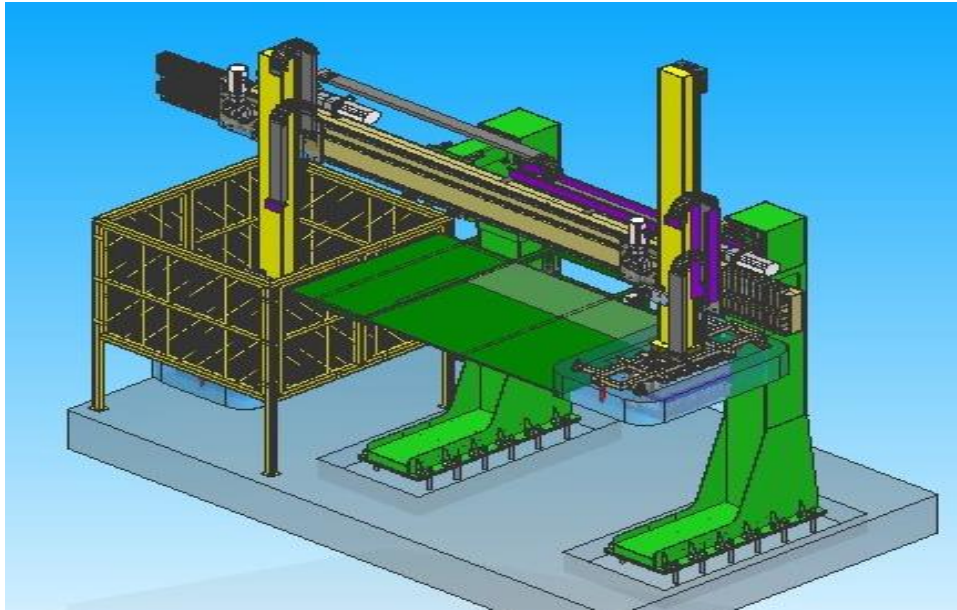

*Ovens For Processing
Industries.*

*50 Ton Job Pre-heating @
170 Deg. Cen. and
Vacuume Impregnation &
Curing Process*

*GAS FIRED OVEN FOR PRE-HEATING & IMPREGNATION
APPLICATION*



OVEN - PHOTOS DURING MANUFACTURING @ OUR FACTORY

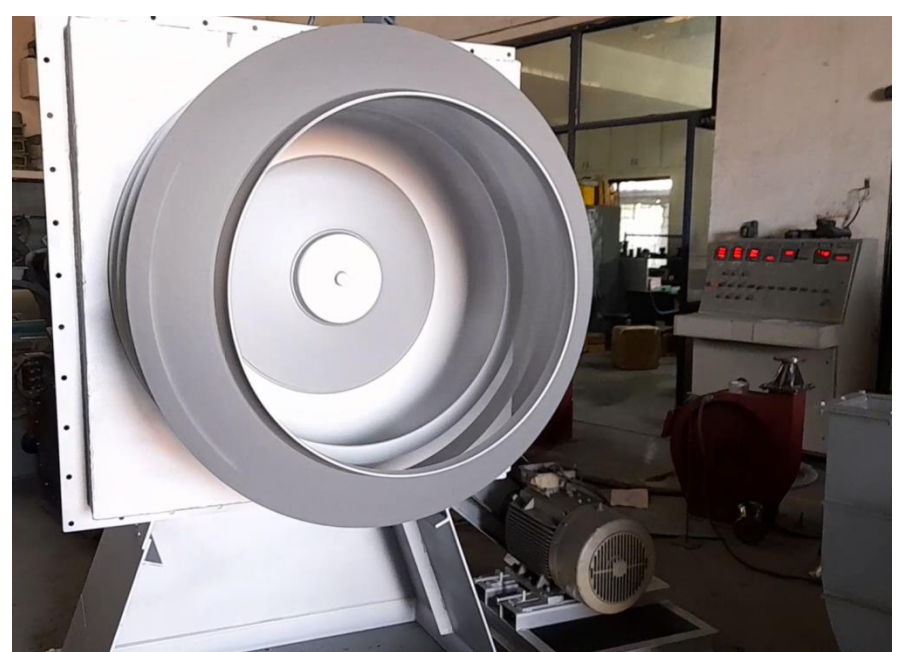

OVEN - PHOTOS AFTER SUCCESSFUL INSTALLATION & COMMISSIONING @ ERODE CHENNAI SITE



*Robotic Applications –
Using 6 Axis Robots and
Cobots*

WINDSHIELD SEALANT DISPENSING LINE- HCIL NOIDA



KNUCKLE X-RAY MACHINE FOR CRACK DETECTION

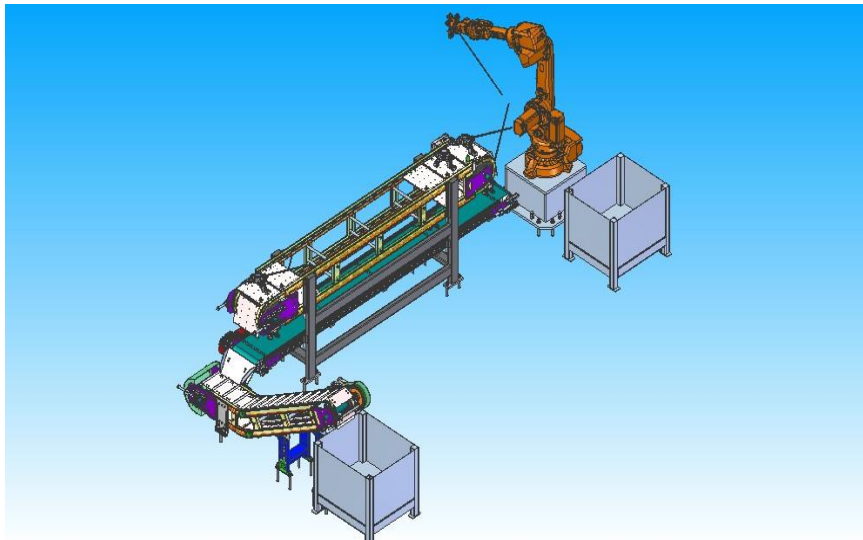
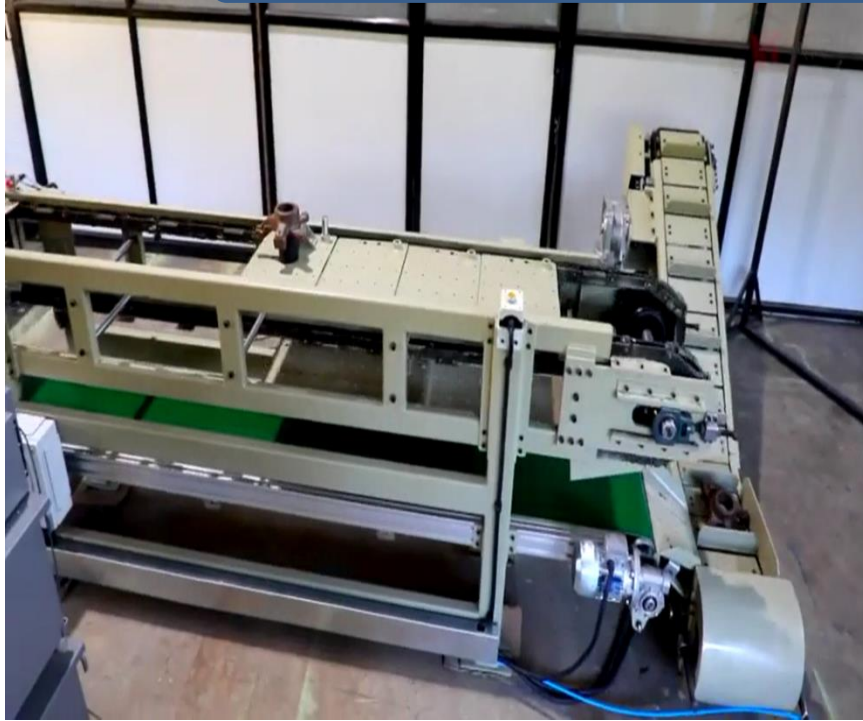

Automated Welding Systems
for BIW Chassis or Two Wheel Chassis welding and other all
welding applications



ROBOTIC PALLETISERS



Cobot & slides for Inspection of Nuclear Fuels

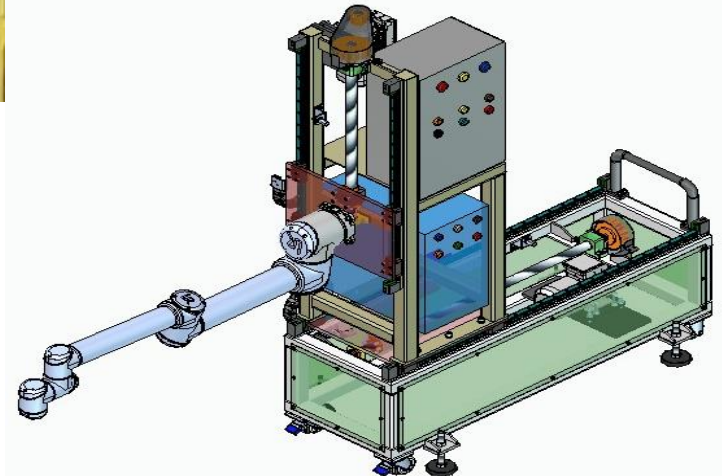

*Some Projects Executed
for Engineering Design
Services*

*BAR END CHAMFERING HIGH SPEED
AUTOMATION SYSTEM*

BAR HANDLING SYSTEMS

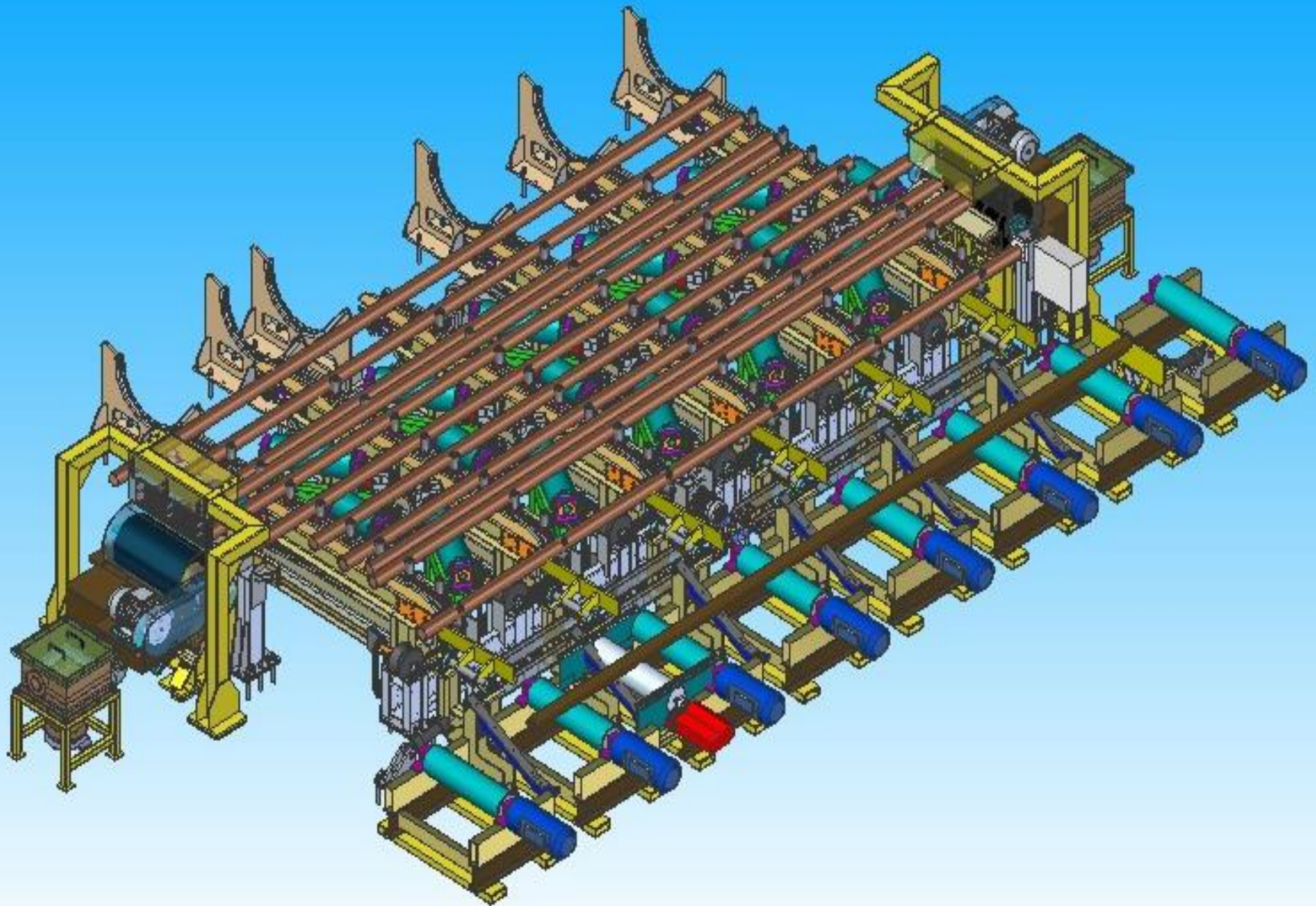

ACID PICKLING & WASHING MACHINE FOR SMALL COMPONENTS

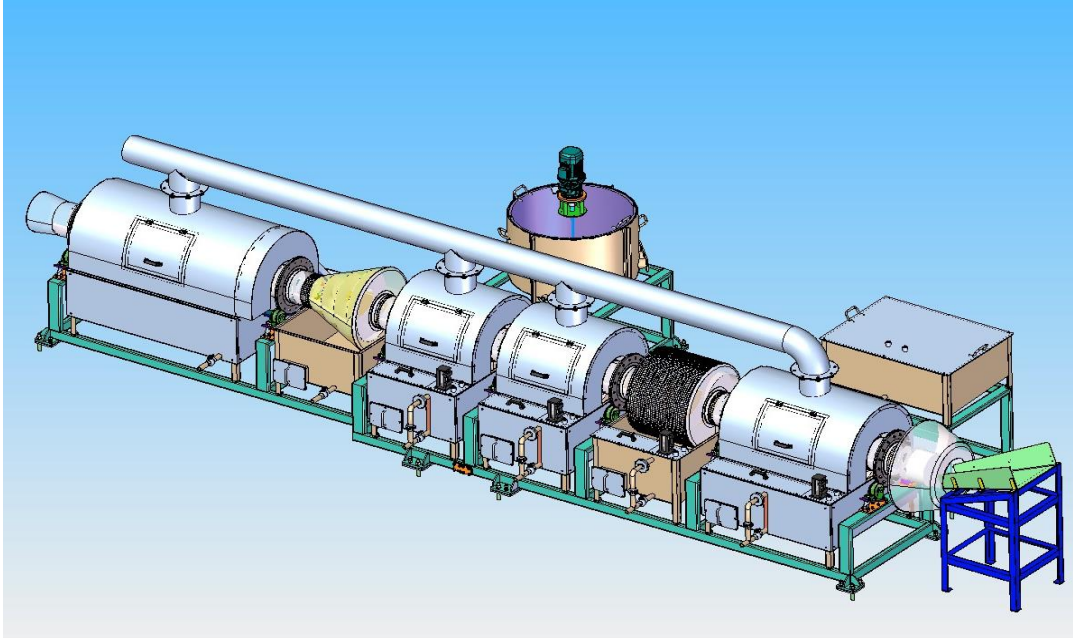

BAIRED BARREL – BULLET FINISHING MACHINE

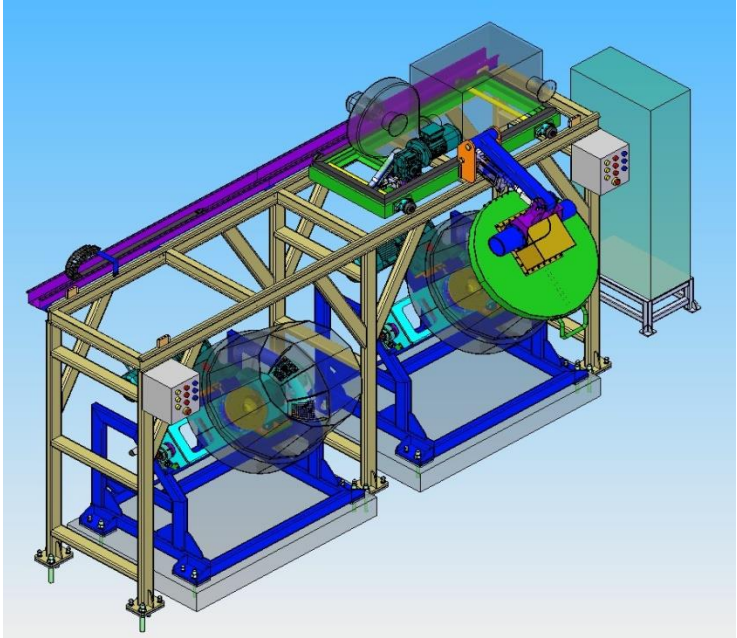

CHAIN CLEANING SYSTEM

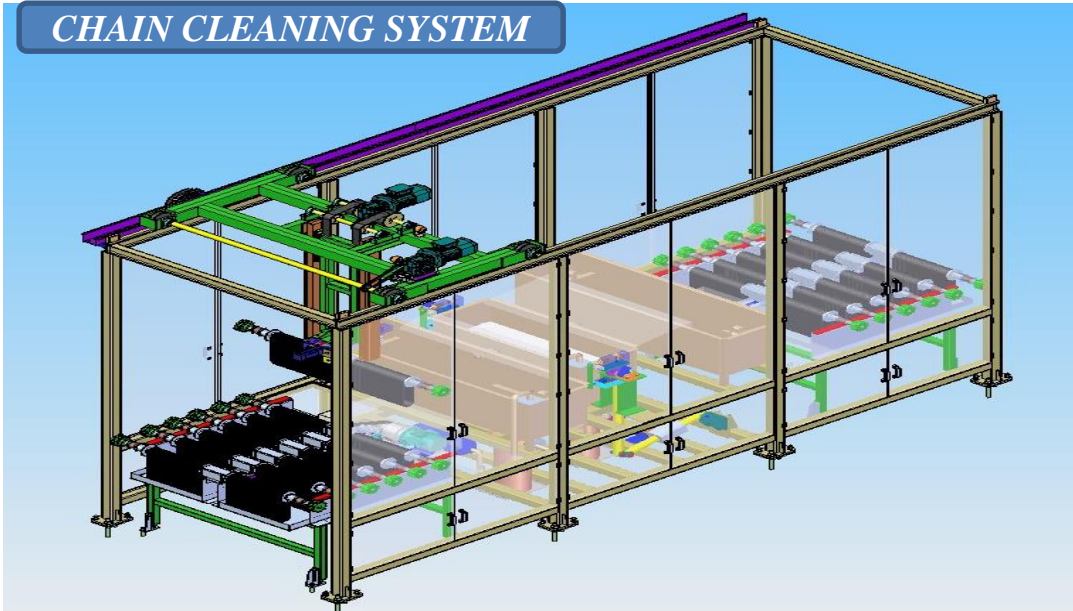

CENTRIFUGAL BARREL POLISHING MACHINE

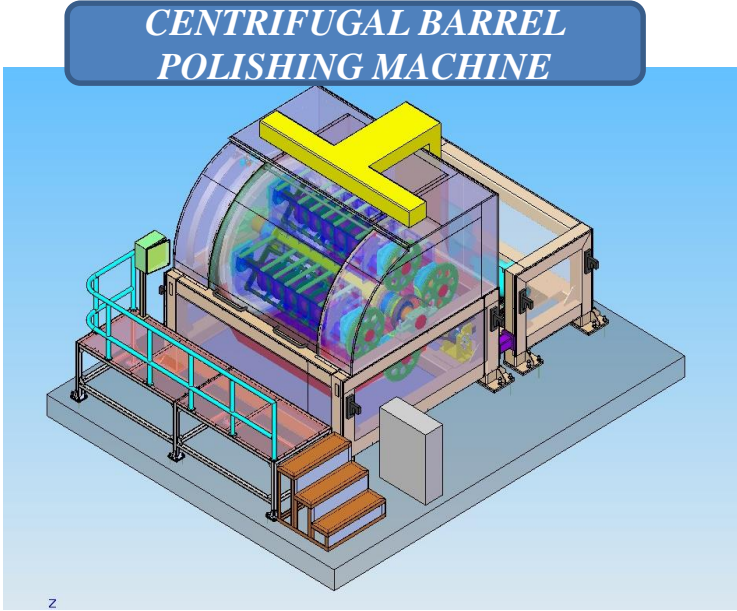

DISC FINISHING MACHINE AUTOMATION

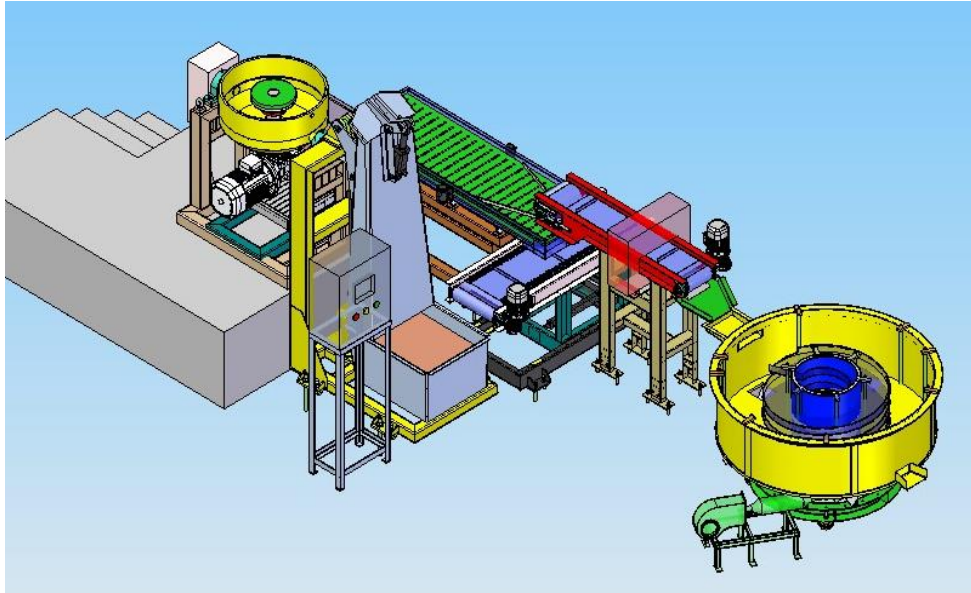

VIBRO BOWL FINISHING AUTOMATION

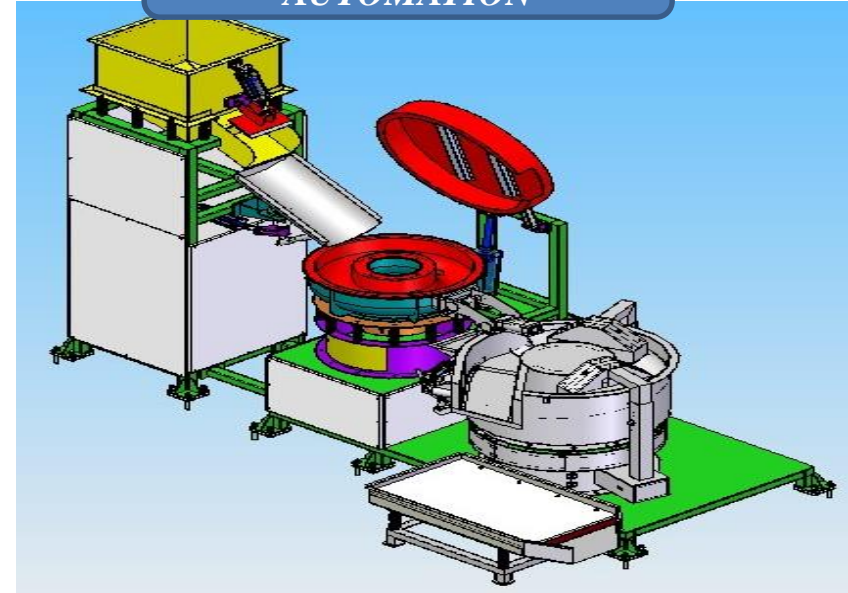

CHAIN COMPONENTS CLEANING SYSTEM

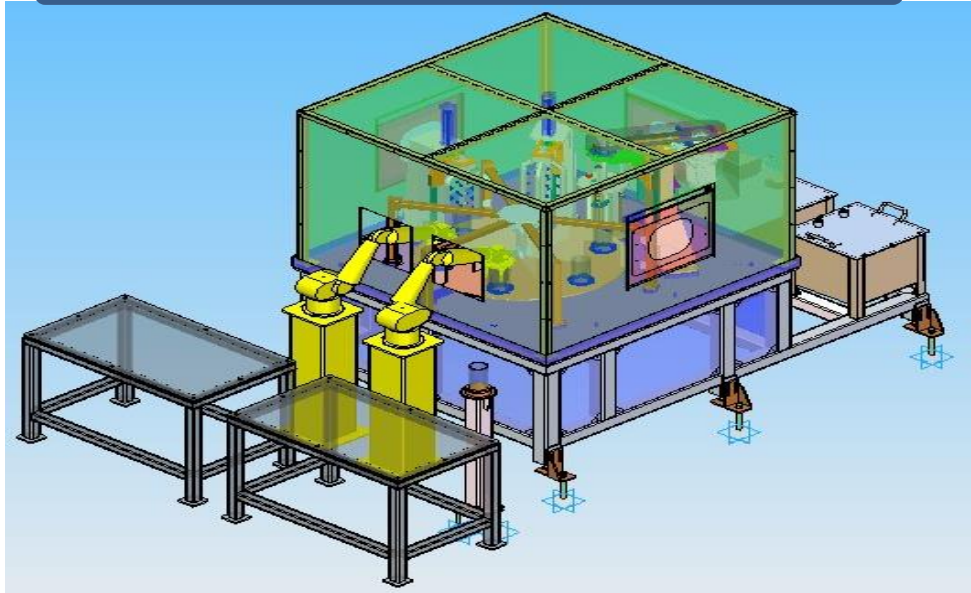

INVESTMENT CASTING CLEANING MACHINE

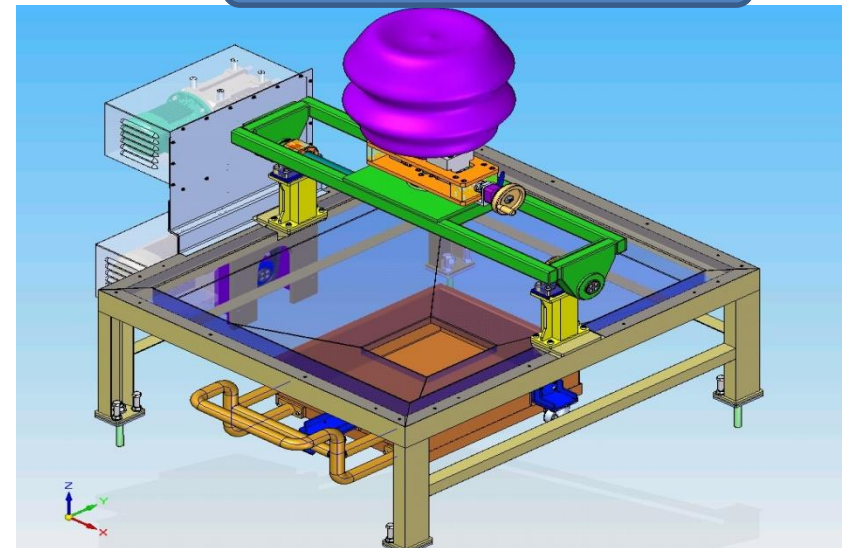

GEOMET COATING MACHINE

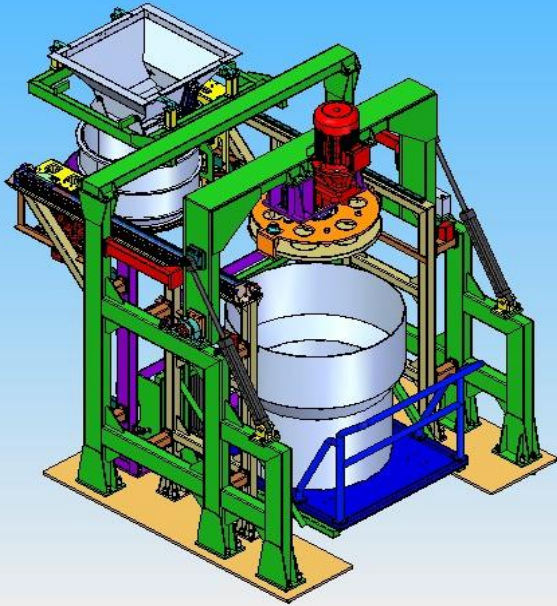

HORLICS SCRAPING MACHINE

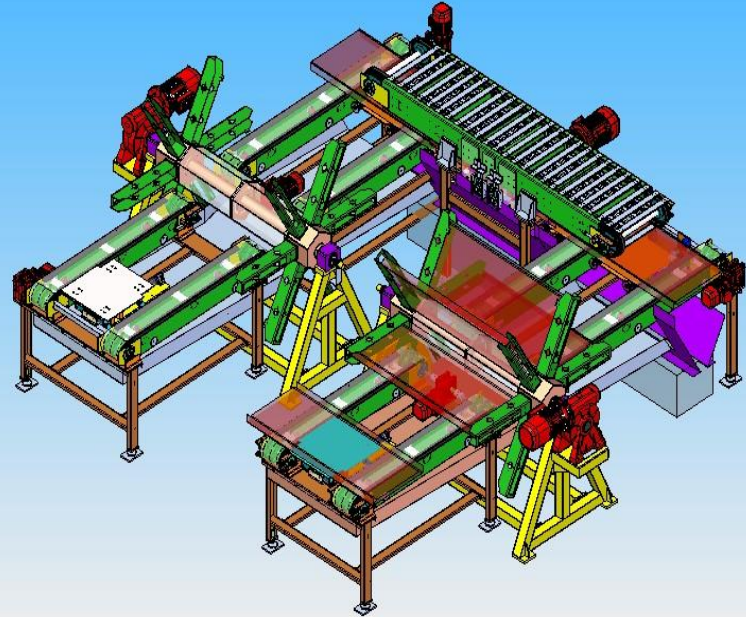

Conveying systems for Warehousing

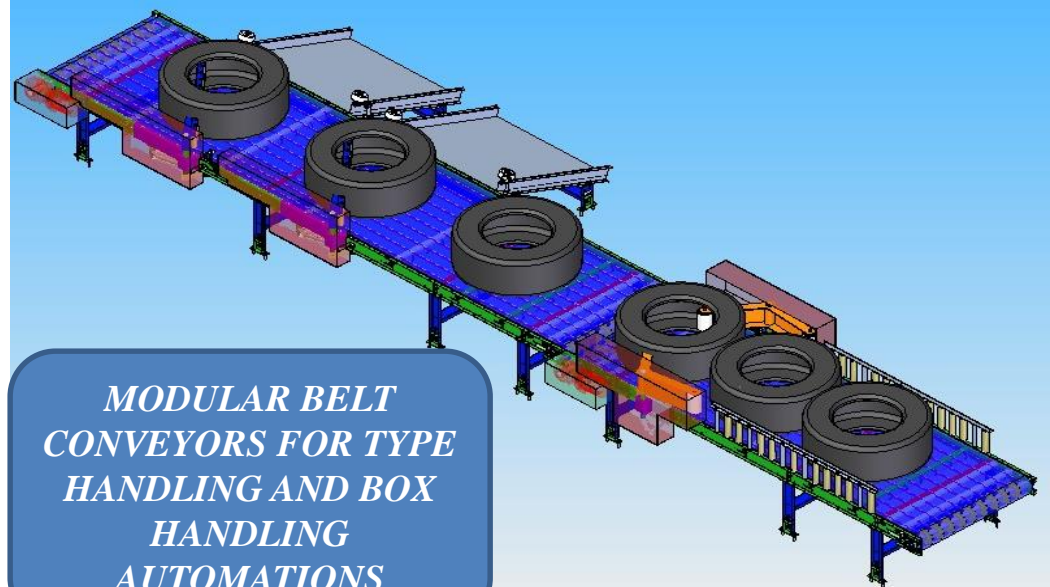

**MODULAR BELT
CONVEYORS FOR TYPE
HANDLING AND BOX
HANDLING
AUTOMATIONS**

4 POST CAR PARKING SYSTEM

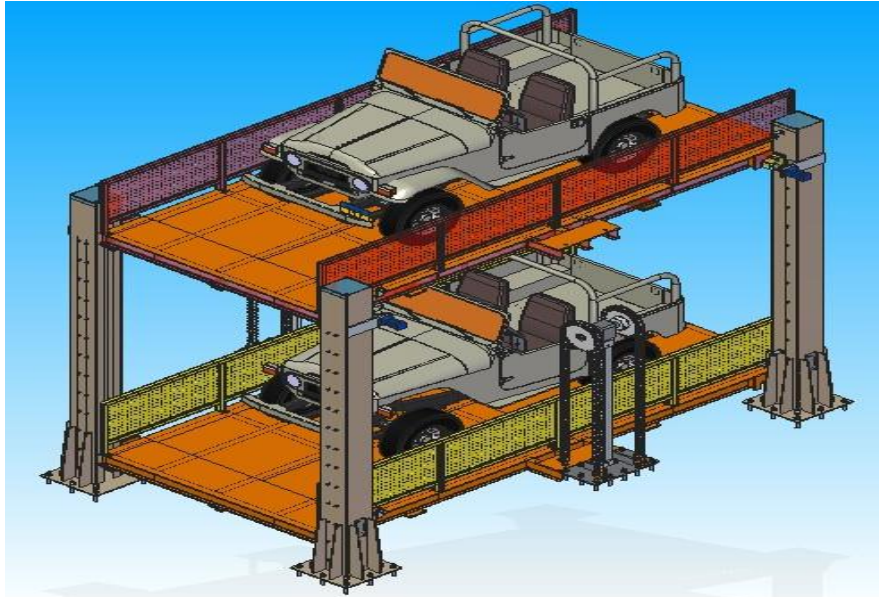

BAR STRAIGHTNESS TESTING MACHINE

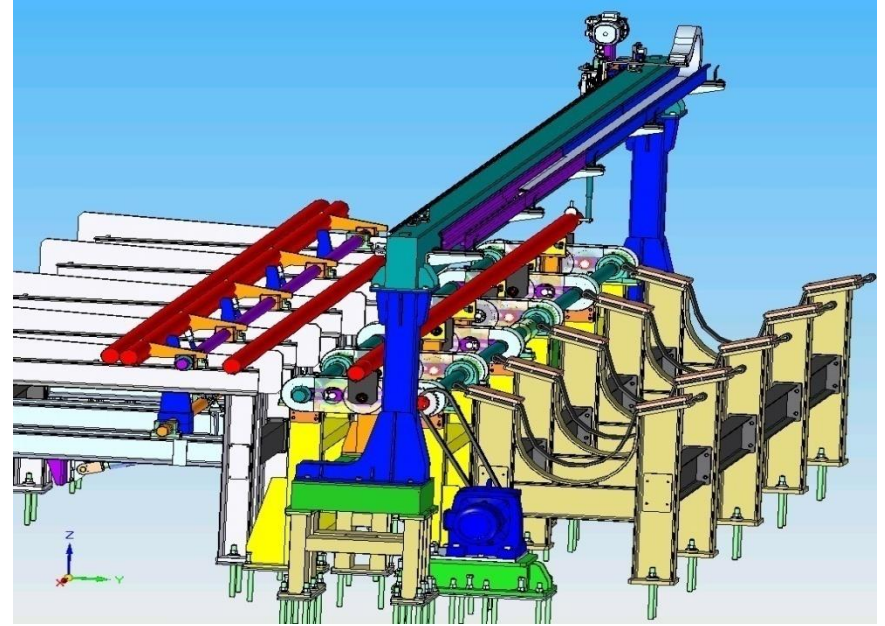

CRATE HANDLING SYSTEM

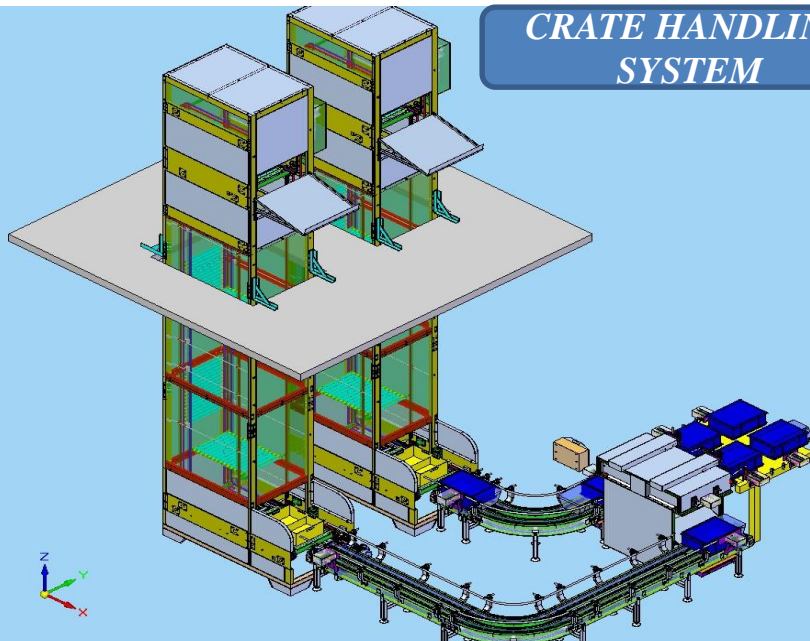

SHEET HANDLING CONVEYOR-STACKER

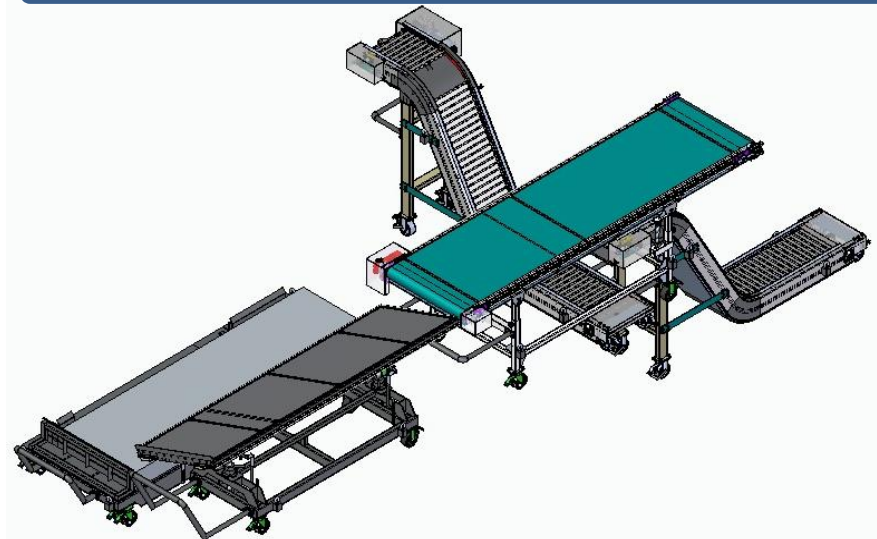

PAPER TUBE CUTTING FINISHING & NOTCHING MACHINES

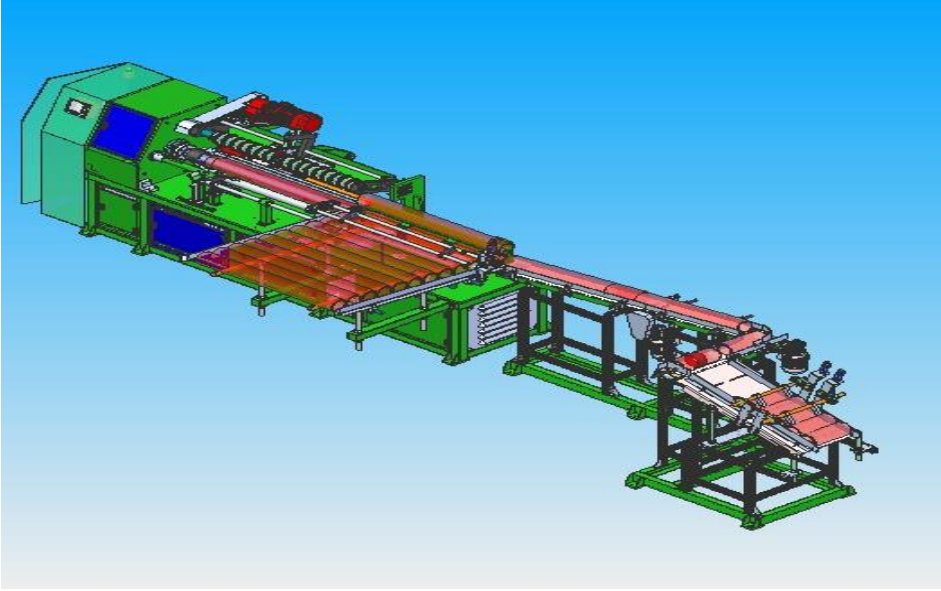

INDEXING TABLE TYPE CLEAT MACKING MACHINES

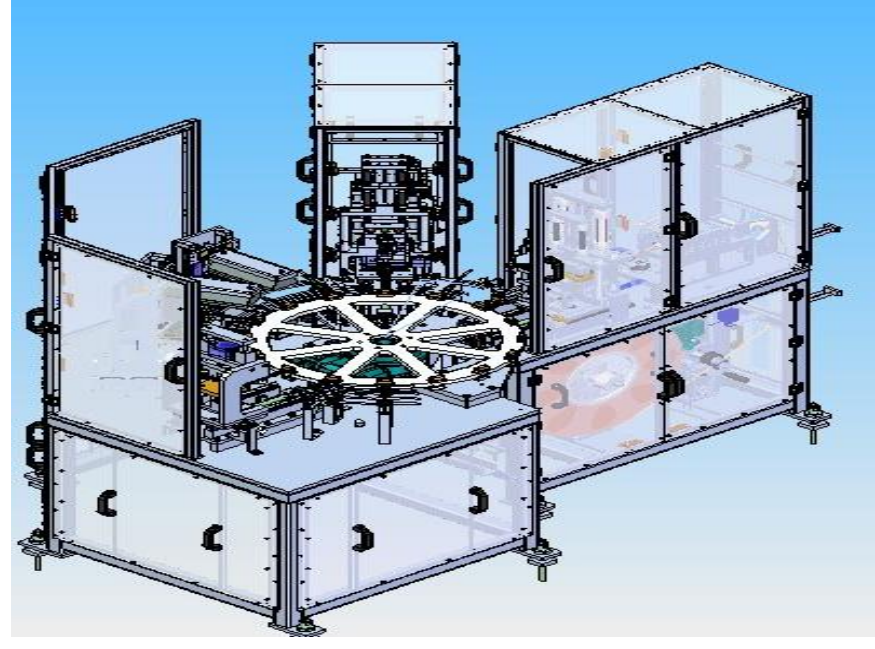

INDEXING TABLE TYPE CLEAT MACKING MACHINES

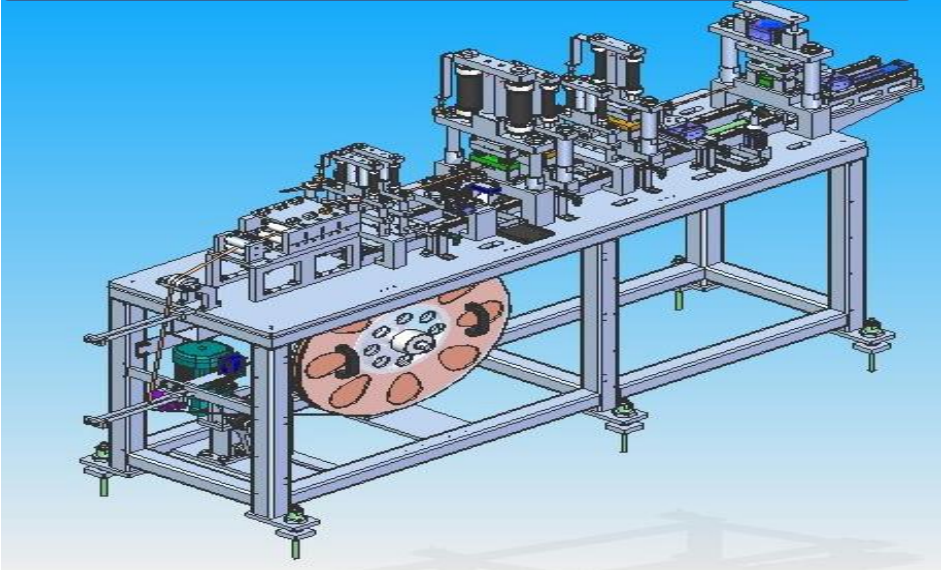

Slat chain Conveyor for Tractor Assembly

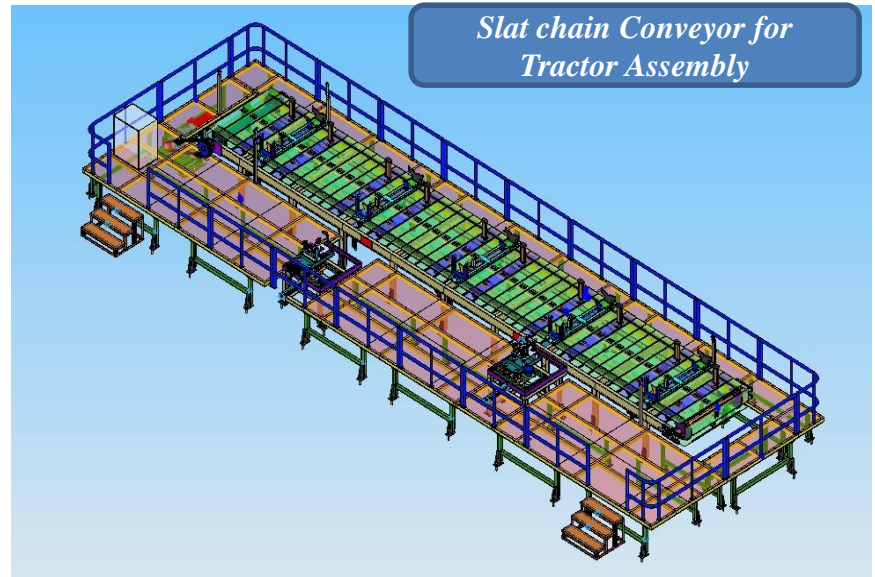

*DIFFERENT TYPE OF OVEN DESIGNS
FOR DIFFERENT APPLICATIONS*

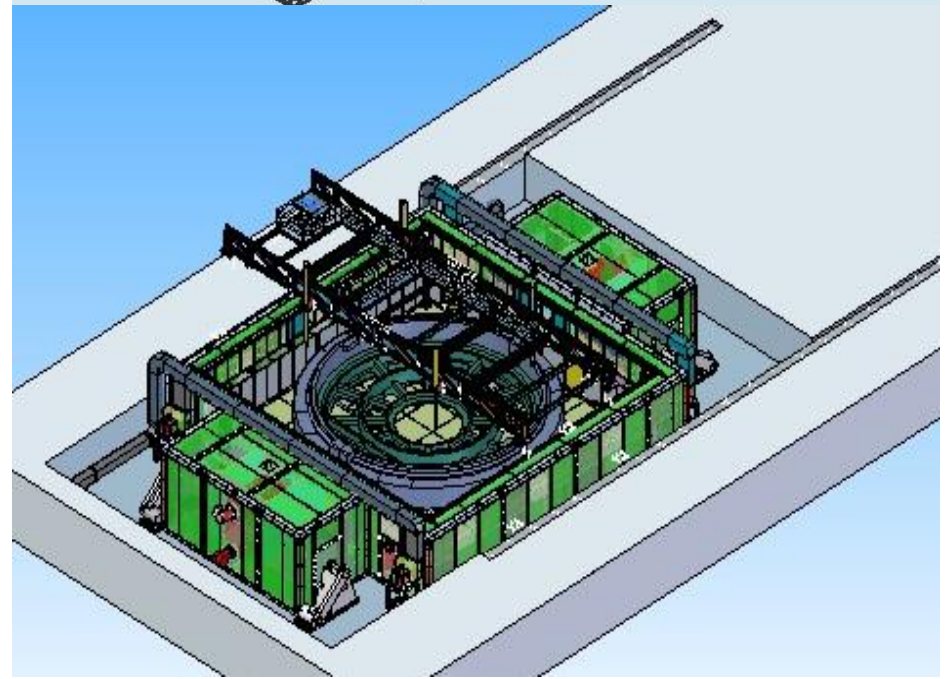
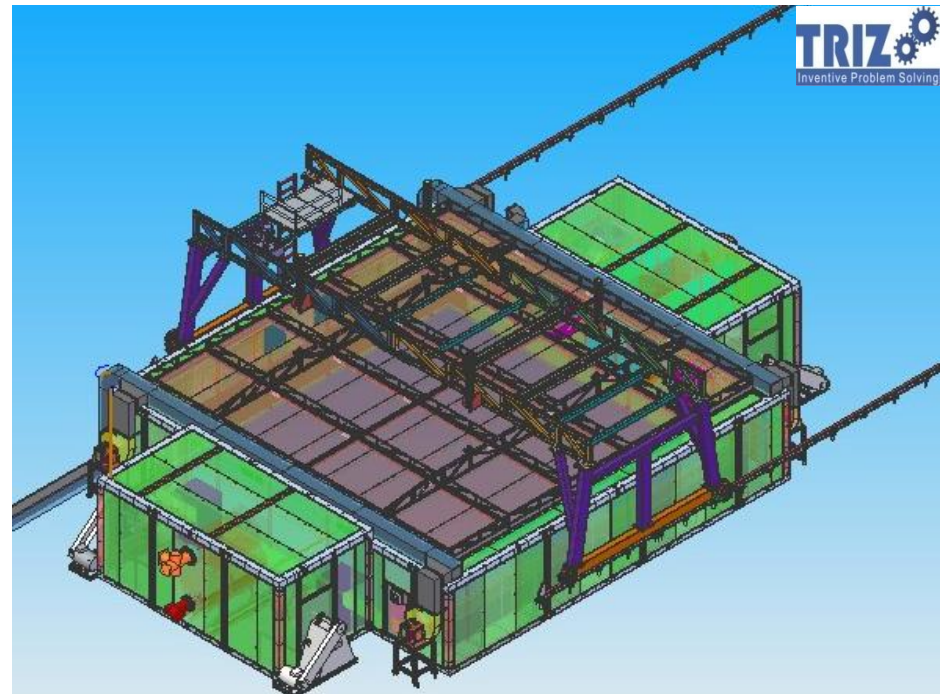
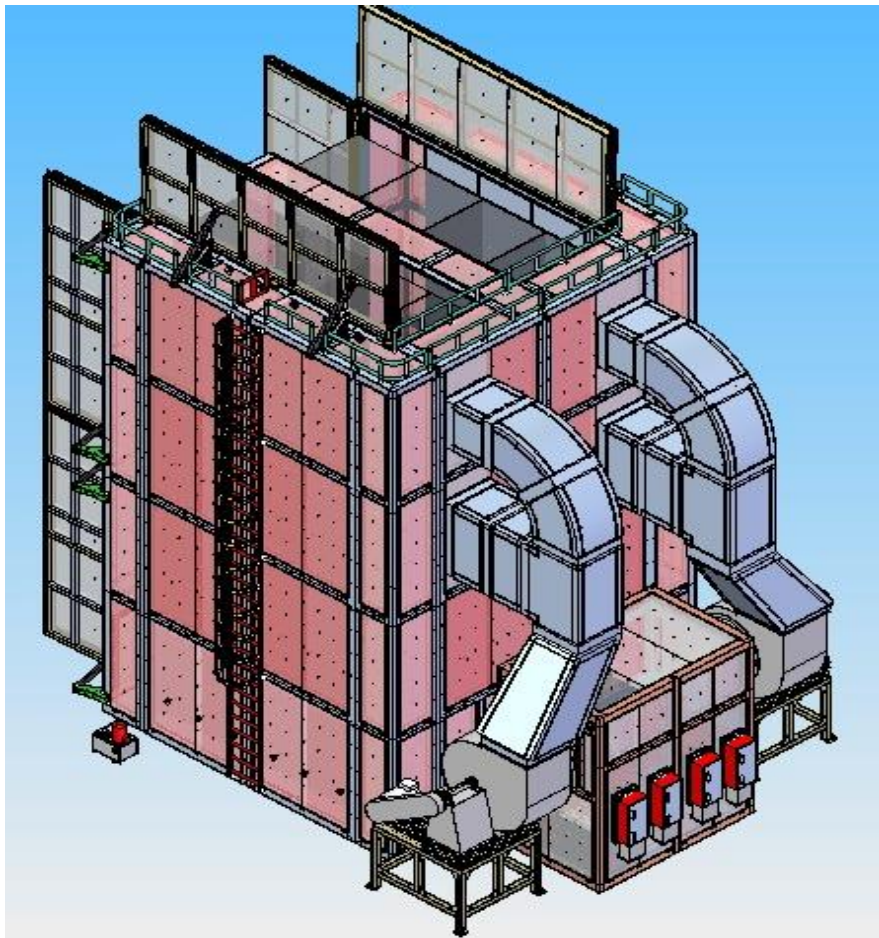

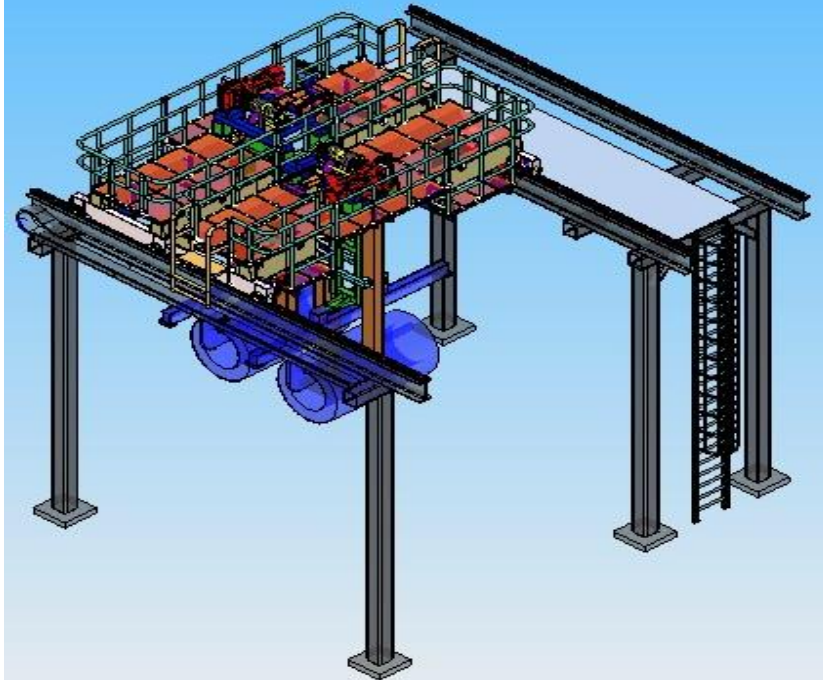
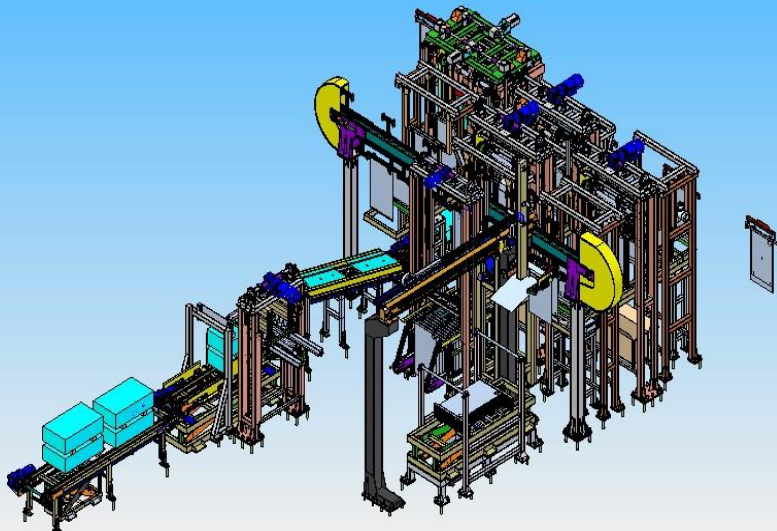
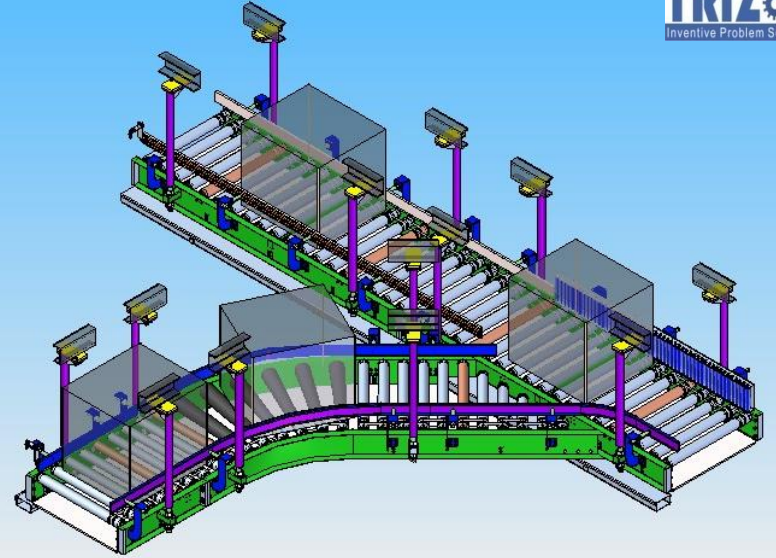
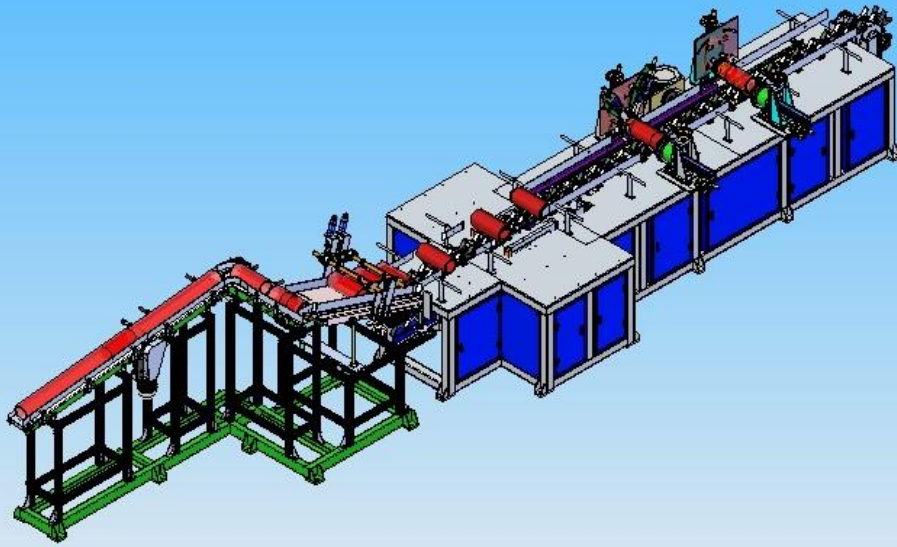

Our Team



OUR CUSTOMERS



HONDA



Thank you.....